



## **Compaq DAT AutoLoader**

Reference Guide

Third Edition (January 2000)  
Part Number 326817-003  
Compaq Computer Corporation

# Notice

The information in this publication is subject to change without notice.

COMPAQ COMPUTER CORPORATION SHALL NOT BE LIABLE FOR TECHNICAL OR EDITORIAL ERRORS OR OMISSIONS CONTAINED HEREIN, NOR FOR INCIDENTAL OR CONSEQUENTIAL DAMAGES RESULTING FROM THE FURNISHING, PERFORMANCE, OR USE OF THIS MATERIAL. THIS INFORMATION IS PROVIDED "AS IS" AND COMPAQ COMPUTER CORPORATION DISCLAIMS ANY WARRANTIES, EXPRESS, IMPLIED OR STATUTORY AND EXPRESSLY DISCLAIMS THE IMPLIED WARRANTIES OF MERCHANTABILITY, FITNESS FOR PARTICULAR PURPOSE, GOOD TITLE AND AGAINST INFRINGEMENT.

This publication contains information protected by copyright. No part of this publication may be photocopied or reproduced in any form without prior written consent from Compaq Computer Corporation.

© 2000 Compaq Computer Corporation.

All rights reserved. Printed in the U.S.A.

The software described in this guide is furnished under a license agreement or nondisclosure agreement. The software may be used or copied only in accordance with the terms of the agreement.

Compaq, Deskpro, Fastart, Compaq Insight Manager, Systempro, Systempro/LT, ProLiant, ROMPaq, SmartStart, ProSignia, registered United States Patent and Trademark Office.

Microsoft, MS-DOS, Windows, and Windows NT are registered trademarks of Microsoft Corporation.

Pentium is a registered trademark and Xeon is a trademark of Intel Corporation.

Other product names mentioned herein may be trademarks and/or registered trademarks of their respective companies.

Compaq DAT AutoLoader Reference Guide  
Third Edition (January 2000)  
Part Number 326817-003

# Contents

## About This Guide

Text Conventions.....	vii
Symbols in Text.....	viii
Symbols on Equipment.....	viii
Rack Stability .....	ix
Getting Help .....	x
Compaq Technical Support .....	x
Compaq Website .....	x
Compaq Authorized Reseller.....	x

## Chapter 1

### Overview

Introduction to the DAT AutoLoader .....	1-1
Features.....	1-2
The SCSI Interface .....	1-3
Controller Requirements.....	1-3
Reliability of Backup Devices .....	1-3
Projected Duty Cycle.....	1-4
Capacity .....	1-4
Data Compression .....	1-4
Cassette Formats.....	1-5
DDS Logo Media .....	1-6
Write-Protecting a Cassette .....	1-7
Life Expectancy of Cassettes.....	1-7

## *Chapter 2*

### **Installation**

DAT AutoLoader Installation .....	2-1
Software and Tool Requirements.....	2-1
Setting the SCSI ID.....	2-3
Switch Settings.....	2-3
Preparing the Computer .....	2-6
Installing the DAT AutoLoader .....	2-6
Reassembling the Computer .....	2-8
Connecting the Tabletop AutoLoader.....	2-9
Completing the Installation .....	2-10

## *Chapter 3*

### **Installing Software Drivers**

Device Drivers .....	3-1
Microsoft Windows NT .....	3-2
Novell NetWare .....	3-3
ASPI Support .....	3-3
Compaq Tru64 UNIX .....	3-4
OpenVMS .....	3-4
SCO OpenServer.....	3-4
Configuring the SCSI ID for SCO OpenServer .....	3-5
SCO UnixWare .....	3-6
SunSoft Solaris.....	3-7
Banyan VINES.....	3-8

## *Chapter 4*

### **Operation**

Introduction to Magazines and Cassettes .....	4-1
Labeling Cassettes and the Magazine .....	4-2
Loading the Magazine with Cassettes.....	4-2
Eight-Cassette Configuration.....	4-3
Seven-Cassette Configuration.....	4-4
Single-Cassette Configuration .....	4-4
To Load the Magazine With Cassettes.....	4-5
Loading the Magazine into the AutoLoader .....	4-6
Removing the Cassettes from the Magazine .....	4-6
Ejecting the Magazine .....	4-7
Modes of Operation .....	4-9
Front Panel.....	4-10
Liquid Crystal Display (LCD) .....	4-11
LCD Messages.....	4-12
LCD Menu Screens.....	4-16

## *Chapter 5*

### **Cleaning**

Importance of Routine Cleaning.....	5-1
Errors Resulting from Cleaning Neglect.....	5-2
Importance of Compaq-Approved Tape Cassettes .....	5-3
DAT AutoLoader Cleaning Recommendations.....	5-3
Procedure for Cleaning the Heads in Stacker Mode .....	5-4
Procedure for Cleaning the Heads in Random Mode .....	5-4

## *Chapter 6*

### **Troubleshooting**

Quick Checklist .....	6-1
Hardware .....	6-1
Software.....	6-2
Installation Troubleshooting.....	6-3
Troubleshooting After Installation.....	6-4
For Tru64 Unix.....	6-4
For Novell NetWare .....	6-4
For Microsoft Windows NT Systems .....	6-5
For SCO OpenServer Systems.....	6-5
For IBM OS/2 Systems.....	6-6
Resolving Operating Problems .....	6-6
Resolving Magazine Problems .....	6-6
Correcting Intermittent Failures.....	6-7

## *Appendix A*

### **Regulatory Compliance Notices**

Regulatory Compliance Identification Numbers .....	A-1
Federal Communications Commission Notice .....	A-1
Class B Equipment .....	A-2
Modifications.....	A-3
Canadian Notice (Avis Canadien) .....	A-4
Class B Equipment .....	A-4
European Union Notice .....	A-4
Japanese Notice .....	A-5
Taiwanese Notice.....	A-5

## *Appendix B*

### **Electrostatic Discharge**

Grounding Methods.....	B-2
------------------------	-----

*Appendix C*

**Specifications**

Dimensions and Weight .....	C-1
Temperature and Humidity Range .....	C-2
Power Requirements .....	C-2
Air-Cooling Requirement .....	C-2
Suspended Particulate .....	C-3

*Index*

# About This Guide

This guide is designed to be used as step-by-step instructions for installation and as a reference for operation, troubleshooting, and future upgrades.

## Text Conventions

This document uses the following conventions to distinguish elements of text:

<b>Keys</b>	Keys appear in boldface. A plus sign (+) between two keys indicates that they should be pressed simultaneously.
USER INPUT	User input appears in a different typeface and in uppercase.
<i>FILENAMES</i>	File names appear in uppercase italics.
Menu Options, Command Names, Dialog Box Names	These elements appear in initial capital letters.
COMMANDS, DIRECTORY NAMES, and DRIVE NAMES	These elements appear in uppercase.
Type	When you are instructed to <i>type</i> information, type the information <b>without</b> pressing the <b>Enter</b> key.
Enter	When you are instructed to <i>enter</i> information, type the information and then press the <b>Enter</b> key.

## Symbols in Text

These symbols may be found in the text of this guide. They have the following meanings.



**WARNING:** Text set off in this manner indicates that failure to follow directions in the warning could result in bodily harm or loss of life.

---



**CAUTION:** Text set off in this manner indicates that failure to follow directions could result in damage to equipment or loss of information.

---

**IMPORTANT:** Text set off in this manner presents clarifying information or specific instructions.

---

**NOTE:** Text set off in this manner presents commentary, sidelights, or interesting points of information.

## Symbols on Equipment

These icons may be located on equipment in areas where hazardous conditions may exist.



Any surface or area of the equipment marked with these symbols indicates the presence of electric shock hazards. Enclosed area contains no operator-serviceable parts.

**WARNING:** To reduce the risk of injury from electric shock hazards, do not open this enclosure.

---



Any RJ-45 receptacle marked with these symbols indicates a Network Interface Connection.

**WARNING:** To reduce the risk of electric shock, fire, or damage to the equipment, do not plug telephone or telecommunications connectors into this receptacle.

---





Any surface or area of the equipment marked with these symbols indicates the presence of a hot surface or hot component. If this surface is contacted, the potential for injury exists.

**WARNING:** To reduce the risk of injury from a hot component, allow the surface to cool before touching.

---

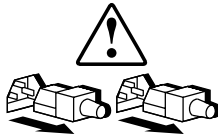

Power supplies or systems marked with these symbols indicate the equipment is supplied by multiple sources of power.

**WARNING:** To reduce the risk of injury from electric shock, remove all power cords to completely disconnect power from the system.

---



Any product or assembly marked with these symbols indicates that the component exceeds the recommended weight for one individual to handle safely.

**WARNING:** To reduce the risk of personal injury or damage to the equipment, observe local occupational health and safety requirements and guidelines for manual material handling.

---

## Rack Stability



**WARNING:** To reduce the risk of personal injury or damage to the equipment, be sure that:

- The leveling jacks are extended to the floor.
  - The full weight of the rack rests on the leveling jacks.
  - The stabilizing feet are attached to the rack if it is a single rack installation.
  - The racks are coupled together in multiple rack installations.
  - A rack may become unstable if more than one component is extended for any reason. Extend only one component at a time.
-

## Getting Help

If you have a problem and have exhausted the information in this guide, you can get further information and other help in the following locations.

### Compaq Technical Support

In North America, call the Compaq Technical Phone Support Center at 1-800-OK-COMPAQ. This service is available 24 hours a day, 7 days a week. For continuous quality improvement, calls may be recorded or monitored.

Outside North America, call the nearest Compaq Technical Support Phone Center. Telephone numbers for world wide Technical Support Centers are listed on the Compaq website. Access the Compaq website by logging on to the Internet at:

<http://www.compaq.com>

Be sure to have the following information available before you call Compaq:

- Technical support registration number (if applicable)
- Product serial number
- Product model name and numbers
- Applicable error messages
- Add-on boards or hardware
- Third-party hardware or software
- Operating system type and revision level

### Compaq Website

The Compaq website has information on this product as well as the latest drivers and Flash ROM images. You can access the Compaq website by logging on to the Internet at:

<http://www.compaq.com>

### Compaq Authorized Reseller

For the name of your nearest Compaq Authorized Reseller:

- In the United States, call 1-800-345-1518.
- In Canada, call 1-800-263-5868.
- Elsewhere, see the Compaq website for locations and telephone numbers.

# Chapter 1

## Overview

### Introduction to the DAT AutoLoader

The Compaq 20/40 Gigabyte (GB) DAT 8-Cassette AutoLoader combines a changer mechanism with a DDS-4 cassette drive mechanism. The DAT AutoLoader houses up to eight DDS cassettes in a removable magazine, which enables you to back up weeks and months of data automatically. High-speed file retrieval and cassette swapping typically allow access to any file in an average of 95 seconds. The DAT AutoLoader supports both sequential and random access modes, with minimum interruption time between cassettes.

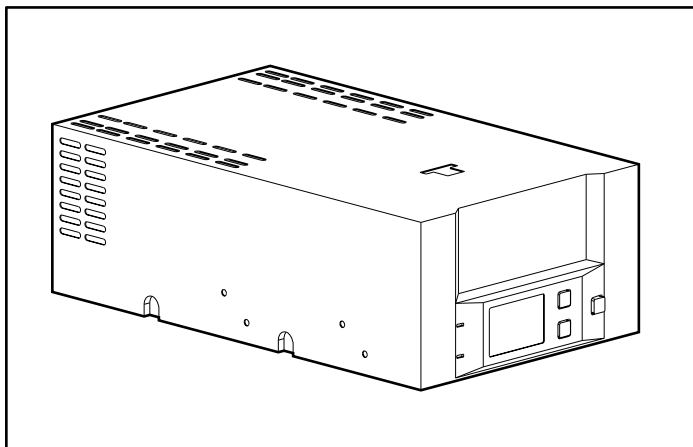

Figure 1-1. Compaq 20/40 GB DAT 8-Cassette AutoLoader

## Features

The Compaq 20/40 GB DAT 8-Cassette AutoLoader offers the following features:

- Any DDS-1, DDS-DC, DDS-2 DDS-3 or DDS-4 cassette can be read or written to, whether data compression is switched on or off.
- The drive is capable of additional sophisticated techniques of error-correction for dealing with cassettes, which are not up to specification.
- When using DDS-4 media, the drive reads and writes the DDS-4 format with a much higher capacity.
- An improved internal cleaning sweeper reduces the frequency of cleaning the heads by a factor of eight.
- The TapeAlert feature allows software and operating systems to warn users of conditions which may occur, such as a cassette nearing the end of its useful life, and to recommend actions that the user can take to recover from the situation.
- A Liquid Crystal Display (LCD) gives clear and comprehensive indications of the status of the DAT AutoLoader.
- A low-cost magazine carrying up to eight DDS cassettes, giving a magazine capacity of 320 gigabytes for DDS-4 cassettes using 2:1 data compression.
- Compatibility with the SCSI-2 Medium Changer command set.
- A common SCSI-2 interface for the drive and changer.
- A standard 5 1/4-inch full-height form factor.
- A cassette odometer displaying the amount of cassette used.

## The SCSI Interface

The Compaq 20/40 GB DAT 8-Cassette AutoLoader uses SCSI-2 as the interface to connect the host system.

---

**IMPORTANT:** In the information that follows, the term SCSI implies SCSI-2.

---

The SCSI implementation provides the DAT AutoLoader with a standard set of features and functions. These include the following:

- LVD Wide SCSI connection
- Synchronous data transfers
- Asynchronous data transfers
- Implementation of all mandatory and most optional commands of the Sequential Access command set
- Full implementation of mandatory Medium Changer commands

## Controller Requirements

Compaq recommends equipping the computer with an LVD 32-bit Fast SCSI-2 Controller or higher. Any of these controllers fully support the Compaq 20/40 GB DAT 8 Cassette AutoLoader.

---

**IMPORTANT:** All SCSI devices on the same bus must either be internal (within the computer) or in an external storage device, but not both. The exception is a CD-ROM drive, which may be internal when other devices are external or vice versa.

---

## Reliability of Backup Devices

The reliability of any backup device is directly related to its duty cycle (the number of hours per day that the device is in use). For example, if a tape drive designed for 24-GB backups is being used to back up a 100-GB computer, the result on that drive will be a need for accelerated preventive maintenance (especially head cleaning), premature aging, and reliability problems. See Chapter 5 for more information on cleaning requirements.

## Projected Duty Cycle

The projected duty cycle of the Compaq 20/40 GB DAT 8-Cassette AutoLoader is an important consideration in determining the amount of time required for backup of a given system, as well as how often it is necessary to clean the tape drive's read/write heads.

For example, a nightly, unattended complete 18-GB backup is well within the capacity of one 20/40 GB DAT drive. However, at a backup rate of approximately 8GB/hour, that tape drive is in operation for approximately 2 1/4 hours every night of the week. With this amount of usage, the tape drive's read/write heads should be cleaned every 4 to 6 weeks. If the drive heads are not cleaned soft errors and overall backup time increases and eventually causes the drive to fail.

## Capacity

The best method for building hardware reliability into a backup strategy is to ensure that the backup hardware is matched to the computers. Table 1-1 relates various computers with the appropriate tape drives. If you need special, partial backups in addition to the routine backups, select the next larger drive size.

**Table 1-1  
Tape Drive Capacity**

<b>Compaq Tape AutoLoader</b>	<b>Computer Capacity</b>
2/4 GB DAT	2-4 GB or less
4/8 GB DAT	4-8 GB or less
12/24 GB DAT	12-24 GB or less
20/40 GB DAT	20-40 GB or less

## Data Compression

The Compaq 20/40 GB DAT 8-Cassette AutoLoader ships from the factory with data compression enabled for writing. The drive is equipped with onboard DDS-DC hardware, using the Data Compression Lempel Ziv (DCLZ) algorithm. In this mode, data is always compressed when writing to the cassette, but the drive is capable of reading both compressed and uncompressed cassettes.

The DAT AutoLoader uses jumper pins and/or dip switches for settings. Some hardware settings may be overridden by way of software. Consult your backup application software documentation for the data compression enabling and disabling procedure.

For information on jumper pin settings for data compression, see “Configuring the AutoLoader” in Chapter 2.

## Cassette Formats

The Compaq 20/40 GB DAT 8-Cassette AutoLoader supports industry-standard Digital Data Storage (DDS), Digital Data Storage Data Compression (DDS-DC), Digital Data Storage-2 (DDS-2), Digital Data Storage-3 (DDS-3), and Digital Data Storage-4 (DDS-4) formats.

---

**IMPORTANT:** For product reliability Compaq recommends using only cassettes purchased from vendors that have been approved by Compaq (See Table 1-2 for list of approved cassettes).

---

These formats were introduced by the DDS Manufacturers’ Group and are approved by the American National Standards Institute (ANSI) and the European Computer Manufacturers’ Association (ECMA). The DDS-DC format is a superset of the DDS format, ensuring backward compatibility with uncompressed cassettes.

To use the full potential of a DDS-format drive, you should use matching cassettes, that is, DDS-4 cassettes for DDS-4 drives. This allows the drives to store the maximum amount of data on a cassette. Refer to Table 1-2 for a list of Compaq approved cassettes.

---

**Table 1-2**  
**Compaq Approved Cassettes**

DDS1	DDS2	DDS3	DDS4
Sony 60m, (DG-60M)		Sony 125m, (DGD-125m)	
Fuji 90m, (DG-90M)	Fuji 120m, (DG-120M)	Fuji 125m, (DG3-125m)	Fuji 150m, (DG4-150m)
	Maxell 120m, HS 4/120s	Maxell 125m, HS 4/125s	Maxell 150m, HS 4/150s

---

**Note:** A DDS-4 drive can read and write to DDS-3, DDS-2, or DDS-1 cassettes.

---

## DDS Logo Media

To identify computer-grade DDS media easily, look for the DDS logos (See Figure 1-2), including ❶ DDS-1, ❷ DDS-2, ❸ DDS-3, and ❹ DDS-4. These indicate that the media meets the DDS specifications laid down by the ECMA, ISO/IEC and ANSI standards.

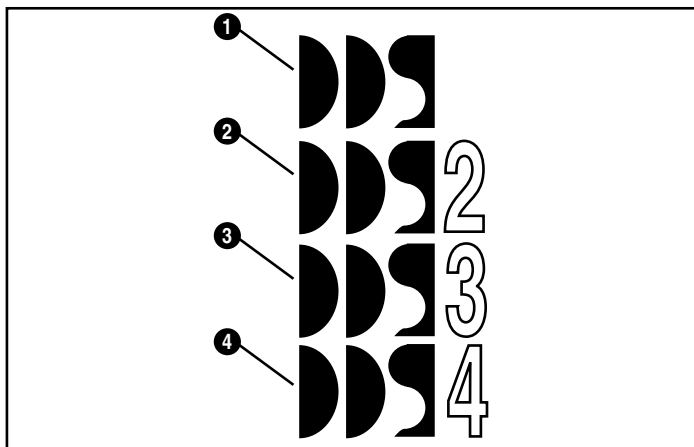

Figure 1-2. DDS Logo Media

The Media Recognition System (MRS) enables drives to identify DDS-grade media. DDS MRS cassettes have a series of stripes on the transparent leader at the beginning of the cassette. The drive can be configured to treat non-MRS cassettes as write-protected. In other words, the drive is only allowed to read non-MRS cassettes, not write to them.



## Write-Protecting a Cassette

---

**IMPORTANT:** The cassette log, which contains a history of usage of the cassette, is updated during the unload procedure. If the cassette is write-protected, the cassette log will not be updated and will be inaccurate.

---

Cassettes can be write-protected by ❶ sliding the tab on the rear of the cassette to the left so that the hole is open (See Figure 1-3). In this state, data can be read from the cassette but not written to it. To remove write-protection, ❷ slide the tab to the right so that the hole is closed.

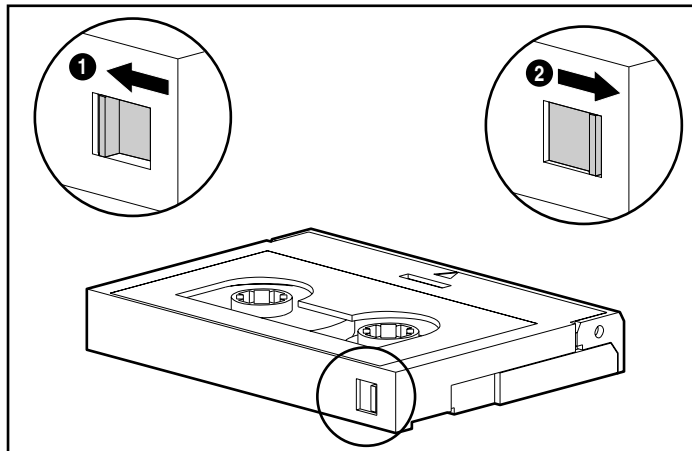

Figure 1-3. Write-protecting a cassette  
 (❶ = Write-protection ON, ❷ = Write-protection OFF)

## Life Expectancy of Cassettes

All DDS-certified media are designed to withstand at least 2000 passes. Under optimum environmental conditions (50% relative humidity, 22°C), this is equivalent to about 100 to 150 backup operations. The life expectancy takes into account that an area of a cassette may have several passes during a backup, either because streaming (the optimum performance rate where data is sent to the drive at approximately the same speed as it is written to the cassette media) cannot be maintained, or because the backup software package repeatedly accesses certain areas of a cassette.

Certain extreme (worst case) conditions reduce the recommended maximum number of backup operations. These conditions are as follows:

- Environmental conditions — Sustained use at the low end of the humidity specification reduces the cassette life.

- **Computer performance** — The lower the performance of the computer, the more likely that streaming cannot be maintained and that an increase in the number of passes over given areas of a cassette will occur.
- **Backup Software** — The backup software may frequently access certain areas of a cassette, or there may be a high system overhead that can cause streaming to stop. Both of these factors increase the number of cassette passes in a given area.

Because these parameters vary from system to system, it is difficult to give a definitive statement of the number of backup operations achievable using a particular cassette.

As a guideline, Compaq recommends using a cassette for approximately 75 backup operations in worst-case conditions such as those listed above.

# *Chapter 2*

## **Installation**

### **DAT AutoLoader Installation**

This chapter describes the procedure to install a Compaq 20/40 GB DAT 8-Cassette AutoLoader in a Compaq computer. In addition, at the end of the chapter there are instructions for connecting the tabletop DAT AutoLoader to a Compaq computer.

Installation involves the following steps:

1. Configuring the DAT AutoLoader
2. Preparing the computer
3. Installing the DAT AutoLoader
4. Reassembling the computer
5. Completing the installation

### **Software and Tool Requirements**

The following items are required for Compaq 20/40 GB DAT 8-Cassette AutoLoader installations:

- Torx T-10 screwdriver
- Torx T-15 screwdriver

- Compaq SmartStart and Support Software CD
- Configuring the AutoLoader

The default hardware settings are set for a Compaq system (see Figure 2-1). The settings in the DAT AutoLoader can be changed if required by a particular system.

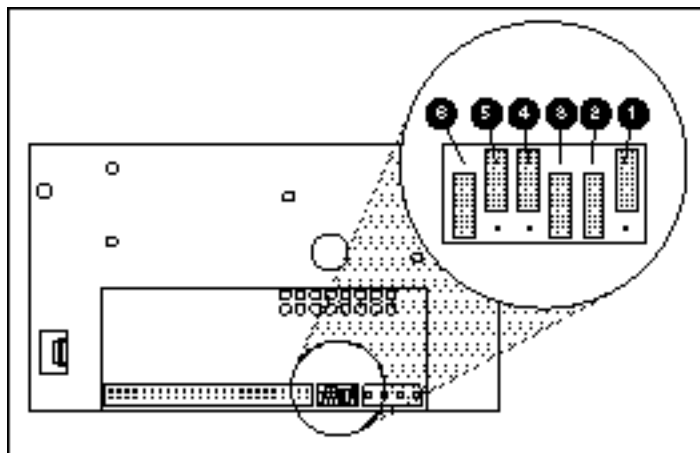

Figure 2-1. Autoloader jumper pins

**Table 2-1**  
**Hardware Settings**

Jumper	Description	Default
①	SCSI ID Bit 0	OFF
②	SCSI ID Bit 1	ON
③	SCSI ID Bit 2	ON
④	Reserved	OFF
⑤	Reserved	OFF
⑥	Parity Enable	ON

**Note:** The default SCSI ID is set to 6. For other settings see, Table 2-2

## Setting the SCSI ID

Each SCSI device on the same SCSI bus must have a unique SCSI ID. Use the jumper block located on the back of the DAT AutoLoader to set the SCSI ID. For SCSI ID jumper settings see Table 2-2.

**Table 2-2**  
**SCSI Jumper Pins**

SCSI ID	Bit 2	Bit 1	Bit 0
0	0	0	0
1	0	0	1
2	0	1	0
3	0	1	1
4	1	0	0
5	1	0	1
6	1	1	0
7*	1	1	1

**Note:** SCSI ID 7 is reserved for the SCSI controller.

## Switch Settings

When the DAT AutoLoader is powered on, it reads a set of configuration switches on the underside of the drive. See the following sections for switch descriptions and settings.

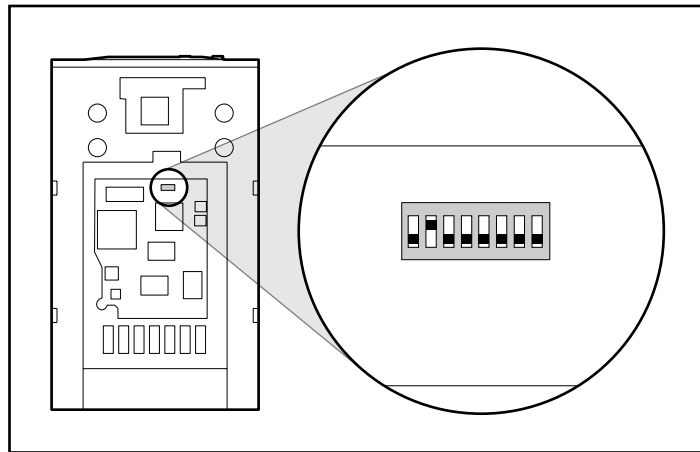

Figure 2-2. AutoLoader configuration switches

**Table 2-3**  
**Switch Settings**

Switch Number	Description	Default
1	Reserved	OFF
2	Reserved	OFF
3	Reserved	OFF
4	Reserved	OFF
5	Terminator Power	OFF
6	Reserved	OFF
7	DC Control-1	OFF
8	DC Control-2	OFF

**Note:** Switch 1 must remain in the OFF position.

Default setting compression at power-on enable the host to control compression.

---

**Table 2-4**  
**Data Compression Definitions**

---

<b>DC Control-1</b>	<b>DC Control-2</b>	<b>Definition</b>
OFF	OFF	Compression disabled at power-on. The host is allowed to control compression.
OFF	ON	Compression disabled at power-on. The host is not allowed to control compression.
ON	OFF	Compression enabled at power-on. The host is allowed to control compression.
ON	ON	Compression enabled at power-on. The host is not allowed to control compression.

---

## Preparing the Computer



**CAUTION:** Electrostatic discharge (ESD) can damage electronic components. Be sure you are properly grounded before beginning this procedure. See Appendix B, “Electrostatic Discharge” for further information.

To prepare the computer:

1. Perform a normal system shutdown.
2. Turn OFF the computer and all peripheral devices.
3. Disconnect the AC main power cord from the outlet, then from the computer and from all peripheral devices.
4. Disassemble the system to expose the drive bay (see documentation included with your computer for instructions on accessing the removable media drive bays).

## Installing the DAT AutoLoader

**NOTE:** Your computer may differ slightly from the following illustrations.

To install the AutoLoader with drive rails:

1. Slide the DAT AutoLoader partially into an available removable media bay.

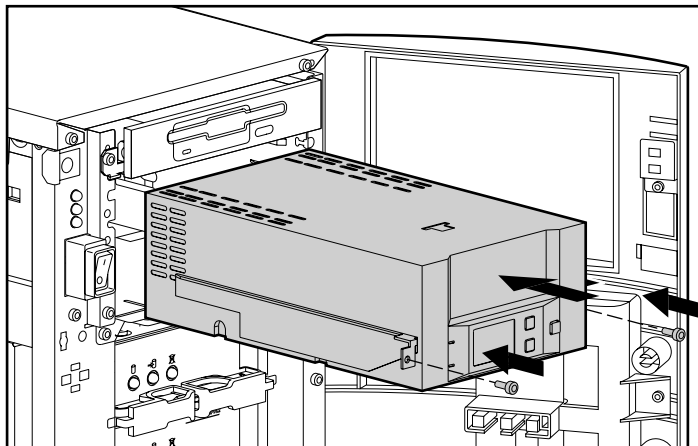

Figure 2-3. Installing the DAT AutoLoader with drive rails



2. Connect the SCSI signal cable and the power cable (supplied).  
(See Figure 2-5.)
3. Carefully slide the DAT AutoLoader the remainder of the way in, adjusting the connecting cables if needed to allow the AutoLoader to be fully inserted.
4. Insert two screws in the front plate using a Torx-15 screwdriver.

To install the Autoloader without drive rails:

1. Remove all screws from drive rails using a Torx-15 screwdriver.
2. Slide the AutoLoader partially into an available removable media bay.

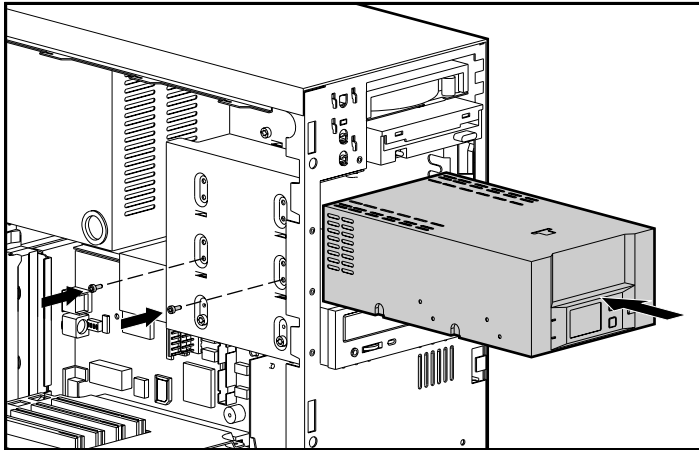

Figure 2-4. Installing the DAT AutoLoader without drive rails

3. Connect the SCSI signal cable and the power cable (supplied).  
(See Figure 2-5.)
4. Carefully slide the DAT AutoLoader the remainder of the way in, adjusting the connecting cables if needed to allow the AutoLoader to be fully inserted.
5. Use the screws that were removed from the drive rails and insert two of them into the threaded mounting holes on each side.

**NOTE:** Some drives may not be accessible on both sides. Secure the sides that are accessible.

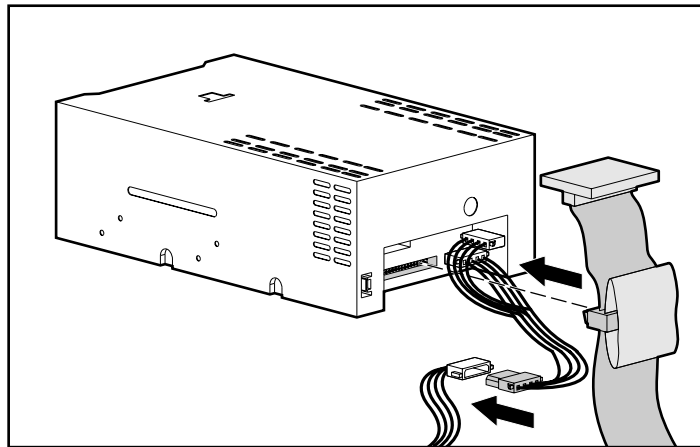

Figure 2-5. Connecting signal and power cables

## Reassembling the Computer

To reassemble the computer:

1. Replace the access panel.
2. Reconnect the peripheral devices to the computer.



**WARNING:** To reduce the risk of electric shock or damage to your equipment, do not disable the power cord grounding feature. This equipment is designed for connection to a grounded (earthed) power outlet. The grounding plug is an important safety feature.

---

3. Plug the AC main power cord into the computer, then plug the cord into a grounded AC outlet.
4. Turn ON all peripheral devices.
5. Turn ON the computer.

## Connecting the Tabletop AutoLoader

For the tabletop DAT AutoLoader, follow the procedures below to connect to a Compaq computer:

1. Set the SCSI ID using the switch at the rear of the DAT AutoLoader (See Figure 2-6). The SCSI ID switch can be adjusted by using a pencil or similar object to click the “+” and “-” buttons. The SCSI ID **default** is **6**.

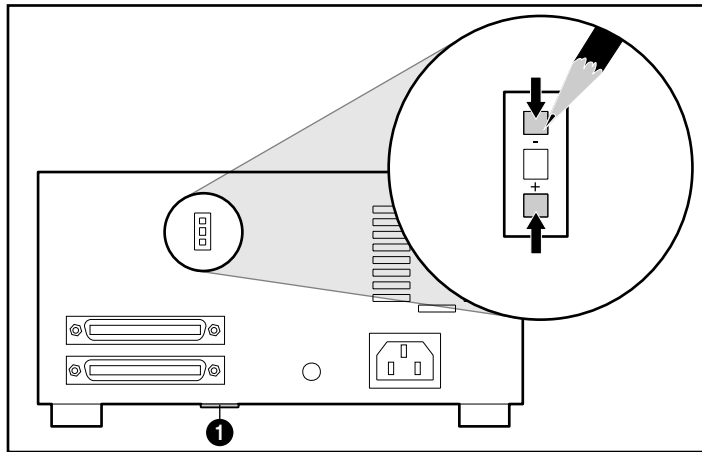

Figure 2-6. External AutoLoader SCSI and options switches

2. Set the configuration switches located on the bottom **1** of the AutoLoader, if required. See the previous section, “Switch Settings,” for switch descriptions and settings.
3. Connect the SCSI signal cable from the computer to one of the two SCSI connectors at the rear of the tabletop DAT AutoLoader.
4. Connect the external terminator (provided with the tabletop DAT AutoLoader kit) to the unused SCSI connector.

**NOTE:** The Compaq-provided LVD/SE terminator will be lit solid red in the single-ended mode. The color red does not indicate an error. (See Figure 2-7.)

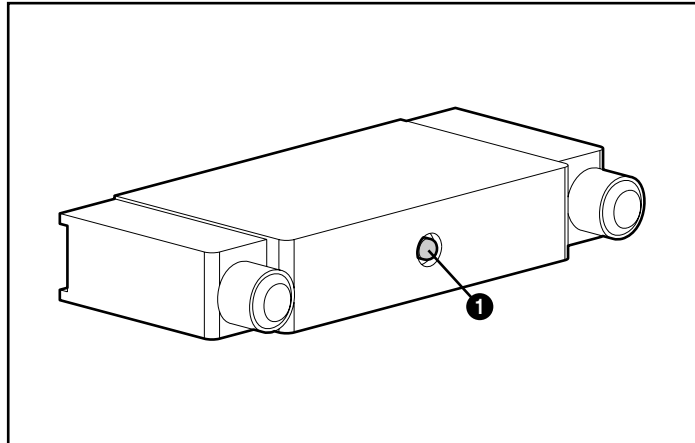

Figure 2-7. Terminator

---

**IMPORTANT:** To “daisy chain” another DAT AutoLoader, remove the external terminator. Connect the SCSI cable between the AutoLoaders and then connect the terminator to the unused connector on the second AutoLoader.

---

5. Connect the power cord.

## Completing the Installation

To complete the installation of the Compaq 20/40 GB DAT 8-Cassette AutoLoader, install the device drivers. See Chapter 3, “Installing Software Drivers,” for specific driver installation information.

## *Chapter* **3**

# Installing Software Drivers

The following operating environments support the AIT tape drives:

- Microsoft Windows NT
- Novell NetWare
- Compaq Tru64 UNIX
- OpenVMS
- SCO OpenServer
- SCO UnixWare
- SunSoft Solaris
- Banyan VINES

## **Device Drivers**

Drivers are located on the Support Software Diskettes and on the Compaq SmartStart and Support Software CD. The drivers on the Support Software Diskettes may be newer versions than drivers you currently are using with new functionality and upgraded utilities. You can use SmartStart to create Support Software Diskettes for specific operating systems.

## Microsoft Windows NT

Drivers for the SCSI controllers and tape drive hardware are located on Support Software Diskettes and on the Compaq SmartStart and Support Software CD. The Support Software ships with each computer or can be downloaded from the Compaq website. The software tape device driver is located either with your tape backup software or with the operating system. Refer to your backup application installation guide for more information regarding additional software that might be needed.

---

**Table 3-1**  
**Microsoft Windows NT**

---

Controller	Software Driver Information
■ 32-Bit Fast SCSI-2 Controllers	Refer to "Compaq SCSI Controller Support" in the <i>NTREADME.HLP</i> file on the Compaq Support Software for Microsoft Windows NT diskette, Version 1.21 or later.
■ 32-Bit Fast-Wide SCSI-2 Controllers	
■ Wide-Ultra SCSI Controllers	
■ LVD Wide SCSI Controllers	

---

**IMPORTANT:** If the SCSI controller to which your drive is attached was not present during your initial Windows NT installation, install the SCSI device driver for the controller **before** installing the tape class driver.

---

Refer to "Compaq Tape Support" in the *NTREADME.HLP* file on the Compaq Support Software for Microsoft Windows NT diskette.

## Novell NetWare

Drivers for the SCSI controller and tape drive hardware are located on Support Software Diskettes and on the Compaq SmartStart and Support Software CD. The Support Software ships with each computer or can be downloaded from the Compaq website. The software tape device driver is located either with your tape backup software or with the operating system. Refer to your backup software application installation guide for more information regarding additional software that might be needed.

---

**Table 3-2**  
**Novell NetWare**

---

Controller	Software Driver Information
■ 32-Bit Fast SCSI-2 Controllers	Run the <i>README.COM</i> file on any of the Novell Software Support Diskettes (NSSD) for driver installation instructions.
■ Wide-Ultra SCSI Controllers	
■ LVD Wide SCSI Controllers	

---

Be sure to load drivers in accordance with the Compaq controller being used.

There are additional driver issues if you wish to use applications requiring the Advanced SCSI Programming Interface (ASPI) support. For more information see the following section.

## ASPI Support

The *README.COM* on the Novell Software Support Diskette (NSSD) outlines the specific drivers you need to support ASPI tape backup applications.

If you are using a tape backup application that uses the ASPI, such as ARCserveIT from Compaq or VERITAS BackupExec, refer to the information provided with your application NLM to determine whether it uses ASPI.

The Compaq ASPI drivers, *CPQSASPI.NLM* Device Driver Functional Specification (DDFS) and *NWASPI.NLM* NetWare Peripheral Architecture (NWPA), provide ASPI support for the Compaq SCSI architecture for applications that require this interface.

All of the required drivers for ASPI tape support are provided on the Novell Software Support Diskette (NSSD). The Support Software ships with each computer or can be downloaded from the Compaq website.

The *SCSI.RDM* file on the NSSD diskette gives complete instructions on how to load these drivers and troubleshoot any problems.

## Compaq Tru64 UNIX

Drivers for the SCSI controller and tape drive hardware are located on Support Software Diskettes and on the Compaq SmartStart and Support Software CD. The Support Software ships with each computer or can be downloaded from the Compaq website. Software support is version 4.0F or later.

The Tru64 UNIX operating system uses Dynamic Device Recognition (DDR), which allows the operating system to recognize the DAT drive without a software tape device driver.

If the following message is seen on any version of Tru64 UNIX, it should be considered an informational message only. No action is required.

```
ctape_ioctl: unmapped scsi density code (0x30)-DDR entry needed
```

**NOTE:** If the drivers are unseen after installation, you need to rebuild the kernel. See Chapter 6, "Troubleshooting," for additional information on where to go for help.

## OpenVMS

Drivers for the SCSI controller and tape drive hardware are located on Support Software Diskettes and on the Compaq SmartStart and Support Software CD. The Support Software ships with each computer or can be downloaded from the Compaq website. Software support is version 7.12 or later.

The OpenVMS operating system uses Dynamic Device Recognition (DDR), which allows the operating system to recognize the AIT drive without a software tape device driver.

## SCO OpenServer

The drivers required to support the DAT tape drive under SCO UNIX are:

- The SCO SCSI tape (stp) driver, which is built into SCO OpenServer; see the SCO System Administrator's Guide for information on how to configure the driver.
- An appropriate SCSI controller driver.



Drivers for the SCSI controllers and tape drive hardware are located on the Support Software Diskettes and on the Compaq SmartStart and Support Software CD. The Support Software ships with each computer or can be downloaded from the Compaq website. The software tape device driver is located either with your tape backup software or with the operating system. Refer to your backup application installation guide for more information regarding additional software that might be needed.

**Table 3-3**  
**SCO OpenServer**

Controller	Software Driver Information
■ 32-Bit Fast SCSI-2 Controllers	Refer to the appropriate <i>README</i> on the Compaq Support Software CD.
■ 32-Bit Fast-Wide SCSI-2 Controllers	
■ Wide-Ultra SCSI Controllers	The name of the driver is CHA.
■ LVD Wide SCSI Controllers	

In addition, the appropriate version of the Compaq Extended Feature Supplement (EFS) for SCO OpenServer is required:

- For SCO OpenServer 5, use Compaq EFS version 5.16 or later.

EFS for SCO OpenServer is available on both the Compaq SmartStart and Support Software CD and is installed and configured automatically during a SmartStart installation.

## Configuring the SCSI ID for SCO OpenServer

In the pre-configured kernel used to install SCO OpenServer, the following SCSI IDs are automatically set:

- Disk = 0
- Tape = 2
- CD-ROM = 5

To determine the SCSI ID of the new tape drive (if not known):

1. Run System Configuration and look under “Review or Modify Hardware Settings,” then “View and Edit Details.” The values reported for controller number, target ID, LUN, and bus number are used during `mkdev` tape.
2. Boot the computer to single user mode and run the `mkdev` tape command.

3. Remove the default tape device from controller 0, ID 2.
4. Add the new tape drive to the configuration.
5. Relink the kernel and reboot the computer to multi-user mode.
6. Run the `hwconfig` command to ensure the new tape configuration is correct. The information appears in a line such as:

```
%tape - - - type= S ha=0 id=2 lun=0 ht= ...
```

In the above example, “id=2” indicates that the SCSI ID is 2.

See the section “Setting the SCSI ID,” in Chapter 2 for more information on setting the SCSI ID.

---

**IMPORTANT:** SCO OpenServer’s install kernel only communicates with the first SCSI controller in the system. Remove the generic tape at ID2, then add the correct tape driver using correct ID, bus, and LUN values.

---

## SCO UnixWare

The drivers required to support Compaq SCSI tape drives under SCO UNIX are the SCO SCSI tape (`stp`) driver and an appropriate SCSI controller driver. The `stp` driver is built into SCO UNIX. Consult the SCO System Administrator’s Guide for directions on how to configure the SCSI tape driver.

The table below describes the drivers required to support current Compaq SCSI controllers.

---

**Table 3-4**  
**SCO UnixWare**

---

Controller	Software Driver Information
■ 32-Bit Fast SCSI-2 Controllers	Refer to the documentation accompanying the Compaq Support Software for SCO UnixWare. Versions 2.x to 7.x. or Compaq EFS 2.2x for UnixWare 2.1 or Compaq EFS 7.2x for UnixWare 7.x. The required driver is CPQSC.
■ 32-Bit Fast-Wide SCSI-2 Controllers	
■ Wide-Ultra SCSI Controllers	
■ LVD Wide SCSI Controllers	

---

EFS for SCO UnixWare is available on the Compaq Support Software CD and on Compaq SmartStart. The Compaq EFS for SCO UNIX is installed and configured automatically during a SmartStart installation.

Compaq SmartStart and Support Software ships with each computer or can be downloaded from the Compaq website.

## SunSoft Solaris

The table below provides information on identifying appropriate drivers for SCSI controllers.

**Table 3-5**  
**SunSoft Solaris**

Controller	Software Driver Information
■ 32-Bit Fast SCSI-2 Controllers	For Solaris 2.5.1, refer to the online documentation on the Solaris 2.5.x OS CD and Driver Update II (DUII) version 1.2.1 or higher.
■ 32-Bit Fast-Wide SCSI-2 Controllers	
■ Wide-Ultra SCSI Controllers	For Solaris 2.6, refer to the online documentation on the Solaris 2.6 OS CD and Driver Update 3 (DU3) version 1.2.1 or higher.
■ LVD Wide SCSI Controllers	
	For Solaris 2.7, refer to the Solaris 2.7 Installation Manual. The required driver is CPQNCR.

## Banyan VINES

The table below provides information on identifying appropriate drivers for Compaq SCSI controllers.

**Table 3-6**  
**Banyan VINES**

Controller	Software Driver Information
■ 32-Bit Fast SCSI-2 Controllers	Refer to the documentation from Banyan regarding the “Compaq Fast SCSI-2 / 53C710 EISA SCSI” driver.
■ 32-Bit Fast-Wide SCSI-2 Controllers	
■ Wide-Ultra SCSI Controllers	To ensure proper controller support, the Compaq Peripheral Adapter Support Software for Banyan VINES 6.x, 7.x, and 8.x, version 3.05 or later is required. Refer to the SSD documentation file, <i>README.SSD</i> regarding the “Compaq Wide-Ultra SCSI Controller” driver.
■ LVD Wide SCSI Controllers	

# Chapter 4

## Operation

This chapter describes the following operations of the Compaq DAT AutoLoader:

- Introduction to magazines and cassettes
- Loading the magazine with cassettes
- Loading the magazine into the AutoLoader
- Ejecting magazines and cassettes
- Modes of operation
- Identifying the front panel
- LCD message categories
- LCD menu screens

### Introduction to Magazines and Cassettes

When purchasing DDS cassettes:

- Always use cassettes labeled “DDS Media Recognition System” in the drive. To use the full potential of the drive, make sure that they are DDS-4 cassettes.
- **Never** use DAT cassettes because the media is not certified and they can have a different specification that can cause them to jam in the mechanism (see Chapter 1 for cassette specifications).

## Labeling Cassettes and the Magazine

Each cassette and the magazine should be labeled prior to use. To label a cassette follow the manufacturer's instruction included with each cassette. To label the magazine, place the label on ❶ space provided (see Figure 4-1).

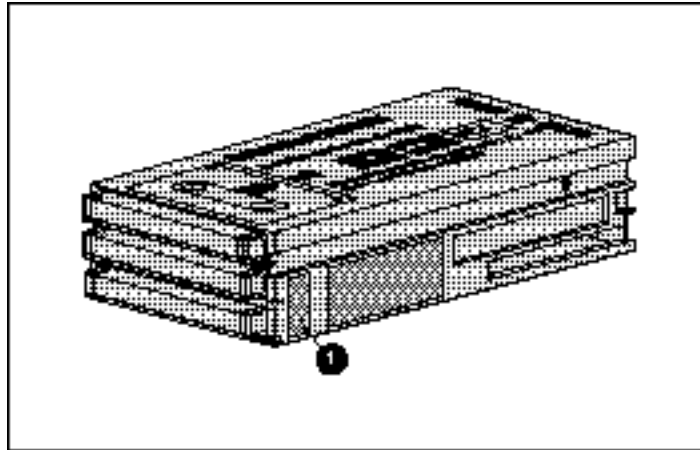

Figure 4-1. Magazine identification

To prevent jams:

- Insert cassettes all the way into the magazine.
- Ensure the label corners are affixed firmly on the cassettes and magazine ❶.
- Only paste labels to the surface and make sure there are no curled edges.
- Never paste labels on top of other labels.

---

**IMPORTANT:** Cassettes should be stored in their magazines so that they are kept together and in the correct order when multi-volumes are backed up.

---

## Loading the Magazine with Cassettes

The magazine holds eight cassettes. There are only three allowable magazine configurations:

- Eight-cassette configuration
- Seven-cassette configuration
- Single-cassette configuration

---

**IMPORTANT:** If the magazine is loaded any other configuration the AutoLoader will not recognize all the cassettes.

---

## Eight-Cassette Configuration

Compaq recommends using this configuration. Place cassettes in all eight positions. Eight data cassettes can be used or seven data cassettes and one cleaning cassette (placed in position 8 only) can be used.

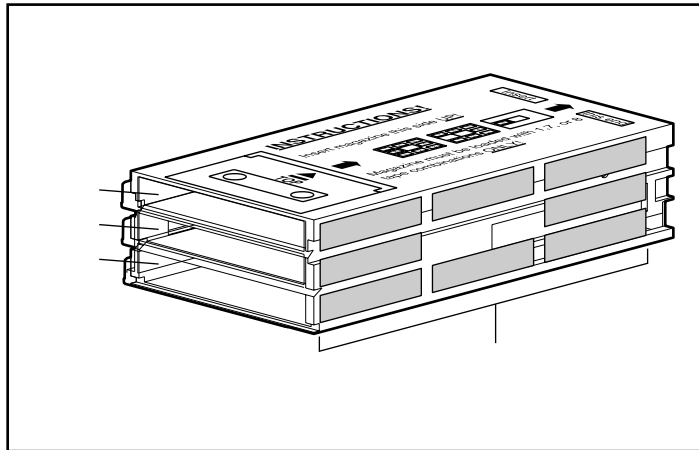

Figure 4-2. Magazine with tape positions

	7	6	5	
Front	8		4	Rear
	1	2	3	

Figure 4-3. Eight cassette positions

## Seven-Cassette Configuration

Cassettes are inserted in all positions except position 8.

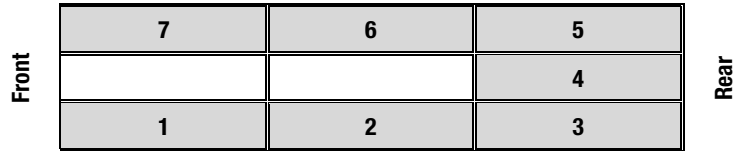

Figure 4-4. Seven cassette positions

## Single-Cassette Configuration

For this operation the cassette must be inserted in position 8. It can be either a data cassette or a cleaning cassette.

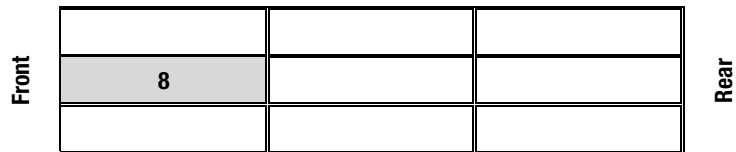

Figure 4-5. Single cassette position

---

**IMPORTANT:** The AutoLoader will:

- Default to a single cassette configuration if there is a cassette in position 8 but less than 7 cassettes in the other positions
  - Eject the magazine if there isn't a cassette in position 8 and all the other positions are not full.
-



## To Load the Magazine With Cassettes

For backup and restore place labeled cassettes into the magazine as described below:

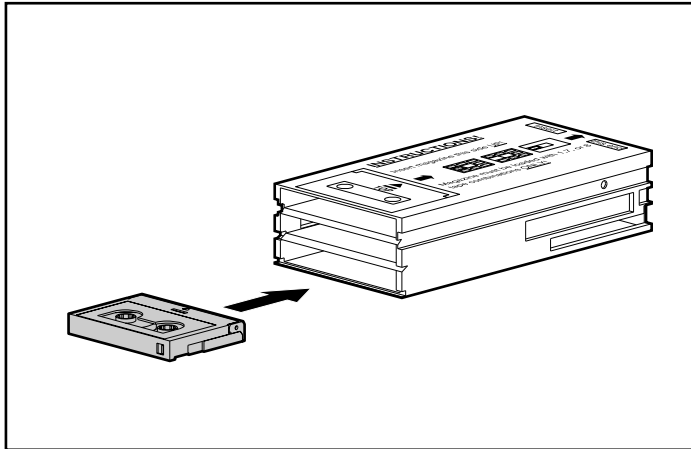

Figure 4-6. Inserting cassettes 3, 2, and 1 into the magazine (Slot 3)

1. Insert the cassettes into the magazine positions in the following order: 3, 2, and 1 (in slot 3). See Figure 4-6.

**NOTE:** Insert the DDS4 logo side up with the logo end going in first.

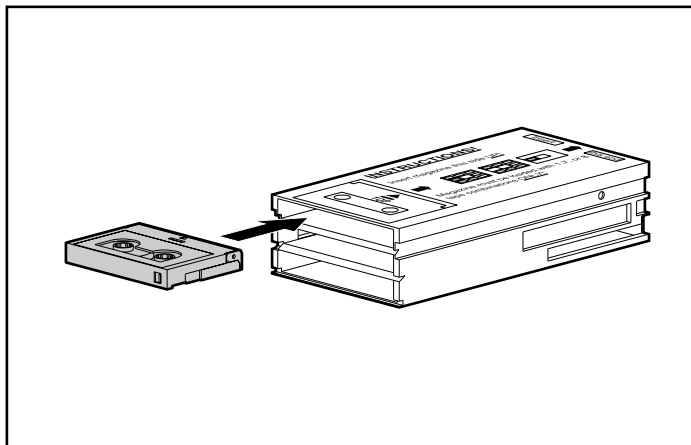

Figure 4-7. Inserting cassettes 4,5,6 and 7 into the magazine (Slot 1)

2. Insert the next four data cassettes in positions: 4, 5, 6, and 7 (in slot 3). See Figure 4-7.

3. For an eight-cassette configuration, insert a cassette in position 8.



**CAUTION:** The cassettes must be loaded in the order they were originally placed during backup.

---

## Loading the Magazine into the AutoLoader

Insert the magazine into the front opening on the AutoLoader in the direction of the arrow. The AutoLoader pulls the magazine in the rest of the way.

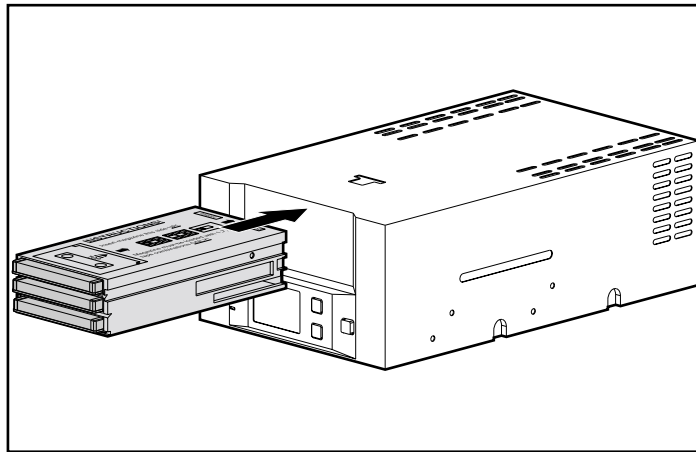

Figure 4-8. Loading the magazine into the DAT AutoLoader

The AutoLoader does a rotation check of the cassettes. If there is an incorrect cassette configuration the AutoLoader ejects the magazine. See “Loading the Magazine with Cassettes” for the correct configurations.

## Removing the Cassettes from the Magazine

**NOTE:** Compaq recommends storing the magazine with the cassettes loaded to ensure they are in the correct order.

1. Hold down the magazine stopper **1** in the direction of the arrow while removing cassettes.

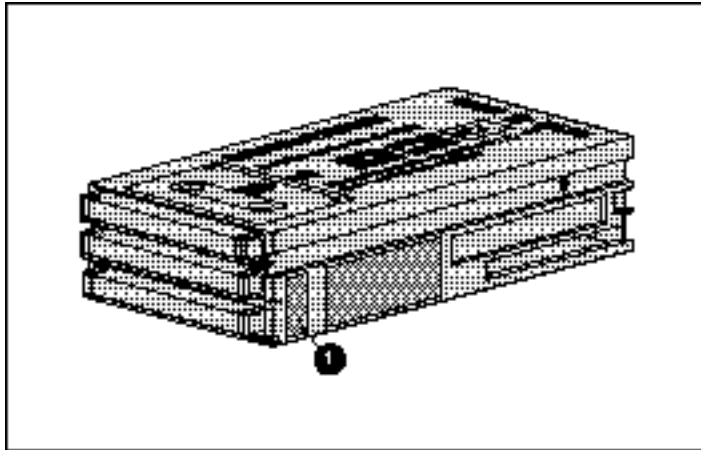

Figure 4-9. Slide stopper

2. To remove cassettes in positions 1 through 5 use the access slots on the bottom of the magazine to slide the cassettes out the front of the magazine.
3. Turn the magazine opening slots up. Gently tap the unit until the cassettes in positions 6 and 7 drop to the bottom slots.
4. Repeat steps 1 and 2.
5. Press the magazine stopper down to pull the cassette from position 8.

## Ejecting the Magazine

To eject a cassette magazine from the DAT AutoLoader, press the **Eject** button or issue an UNLOAD command from the host. The following sequence of events occurs:

1. The tape is rewound to BOP (Beginning of Partition).
2. If the tape is write-enabled, the copy of the tape log held in RAM is written back to the tape.
3. The tape is then rewound to BOM (Beginning of Media) and unthreaded.
4. The AutoLoader replaces the cassettes in the magazine in the correct order.
5. The magazine is ejected.

If the host sends an UNLOAD command (LOAD/UNLOAD with the LOAD bit set to 0), the same procedure is completed, but the magazine is not ejected at the end.

If you press the **Eject** button during the 30 seconds when the DAT AutoLoader checks magazine positions following insertion of a magazine, the magazine is ejected immediately, even if Medium Removal Prevention is in force.

If the host has previously sent a PREVENT MEDIA REMOVAL command, the unloading action is different in two ways:

- The **Eject** button is disabled and has no effect. It does not initiate an unload sequence.
- An UNLOAD command puts the drive into a semi-loaded state. It takes the drive offline and unthreads the tape, but does not eject it.

The effects of PREVENT MEDIA REMOVAL continue until an ENABLE MEDIA REMOVAL command is received, or the drive is reset.

### Forcing Cassette Ejection



**CAUTION:** You can lose data if you force ejection of a tape. The tape may also end up invalidly formatted because EOD (End of Data) may not have been written. Force ejection only as a last resort to recover a cassette. Never use it as a quick way of ejecting a cassette.

---

If you press the **Eject** button when the drive is busy, it may be a long time before the drive responds to the request, because it is finishing the task it is performing first. This method ensures that the task is terminated in a controlled manner, and no data is lost.

However, if you need to unload a cassette urgently, even at the risk of losing data, you must force ejection as follows:

1. Hold the **Eject** button down for at least 5 seconds. The LCD displays “Force Eject.”
2. The DAT AutoLoader waits 35 seconds to give the normal ejection procedure a chance to occur.
3. Once this time has elapsed, if there is a tape loaded in the drive, it is immediately unthreaded and the cassette is ejected, regardless of what operation the drive was performing. The cassette is then returned to its position in the magazine, and the drive is reset as though the power has been cycled.

Because the forced ejection may interrupt any operation, it is possible that the drive will not write EOD (End of Data) before the cassette is ejected. This will cause loss of data, and result in a cassette with an invalid format. However, it should still be possible to read such a cassette up to the point where the ejection interrupted the writing.

4. If no cassette is loaded in the drive, the DAT AutoLoader assumes that you want to eject the magazine. Following the 35 seconds, it does eject the magazine. The DAT AutoLoader is then reset as though power had been cycled.

---

**IMPORTANT:** Forced ejection overrides any SCSI PREVENT MEDIA REMOVAL that may be in effect, and can abort any SCSI operations in which the DAT AutoLoader is engaged.

---

## Modes of Operation

The DAT AutoLoader can operate in either Stacker or Random mode.

### Stacker Mode

In Stacker mode (also known as sequential mode), a cassette can be selected using the **Select** and **Enter** buttons on the front panel. When a cassette is ejected from the embedded drive after a host UNLOAD command, the DAT AutoLoader automatically moves the next available cassette from the magazine into the drive. In this mode the DAT AutoLoader does not depend on the host computer to send SCSI MEDIUM CHANGER commands to move cassettes to and from the magazine.

### Random Mode

The AutoLoader enters this mode when it receives a SCSI MOVE MEDIUM command. The **Select** button is disabled. The **Eject** button or SCSI UNLOAD command will cause the AutoLoader to exit this mode.

## Front Panel

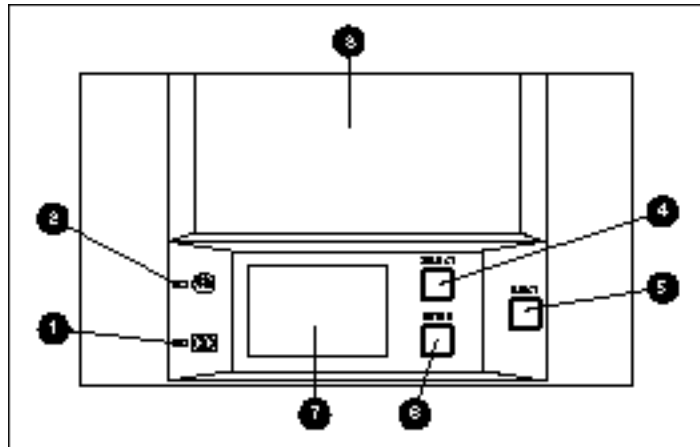

Figure 4-10. Identifying the front panel features

Callout	Description	Feature
①	Tape LED	Shows when a cassette is present
②	Busy LED	Shows when activity is taking place
③	Magazine Position	Where the magazine is inserted and ejected
④	Select button	Selects a cassette for use
⑤	Eject Button	Starts the unload process then ejects
⑥	Enter Button	Confirms cassette selection
⑦	Liquid Crystal Display	Shows the status of the AutoLoader

## Liquid Crystal Display (LCD)

The LCD display provides information about the DAT AutoLoader.

**NOTE:** The exact display shown can never occur; all the sections are shown at the same time to show their location.

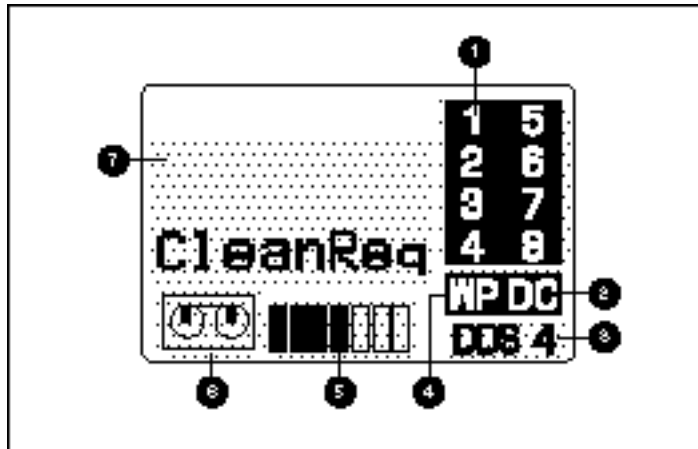

Figure 4-11. Front panel LCD display

Callout	Feature	Callout	Feature
①	Cassette numbers	⑤	Cassette position in drive
②	Data Compression	⑥	Cassette motion in drive
③	Type of Cassette in drive	⑦	Text Area (up to 4 lines)
④	Write Protect Indicator		

## LCD Messages

Front panel LCD messages are provided in list Table 4-1.

**Table 4-1**  
**LCD Messages - Alphabetical Listing**

LCD Message	Message Type	Meaning
Cassette Stuck In Drive	Error	A cassette is stuck in the drive.
Cleaning in Process	Status	A cleaning cassette has been loaded into the drive mechanism and is cleaning the heads. The cleaning cassette will be automatically returned to the magazine when the cleaning cycle is complete.
Cleaning Failed	Error	The cleaning cassette is used up. Replace the cleaning cassette and discard the old one.
CleanReq		
CleanReq	Error	It is time to clean the heads on the drive or a high error rate has been detected reading or writing. Move the cleaning cassette from the magazine to the drive (if necessary, load a cleaning cassette into the magazine). The cleaning cycle will automatically start once the cleaning cassette is loaded in the drive. See "Cleaning in Process."
Drv HW Error 04xxxxxx	Error	This is an embedded-drive hardware error. In some cases the SCSI error code generated will be displayed on the 3 <sup>rd</sup> line as M4sxxsxx where the xx's represent the additional sense code and qualifier.
Eject Prevent	Info	This is displayed when the SCSI command "PREVENT MEDIA REMOVAL" has been set, and the <b>Eject</b> button has been pressed. Th SCSI command prevents the cassette or magazine from ejecting.
Ejecting Magazine	Info	This is displayed after the <b>Eject</b> button is pressed and the magazine is being ejected.

*continued*



**Table 4-1**  
**LCD Messages - Alphabetical Listing** *continued*

LCD Message	Message Type	Meaning
Erase Tape x	Status	The drive is erasing data from the cassette x where x represents the cassette number.
Illegal Cassette Config	Error	This is an error message. A cassette was inserted in the magazine incorrectly. The magazine will be ejected with the incorrect cassette in position 7 or 8. Remove all cassettes and reinsert them correctly, making sure they are put back in the original positions they were in when first loaded in the magazine.
Illegal Magazine Config	Error	This is an error message. This occurs when there is at least one, but less than seven cassettes in positions 1 through 7. The magazine will eject. Reload according to one of the configurations in the section, "Loading the Magazine With Cassettes."
Init Element Status	Info	The AutoLoader is moving all cassettes back to their original positions.
Ldr HW Error ResetReq 04xxxxxx	Error	This is an AutoLoader hardware error. In some cases the 4 <sup>th</sup> line can display additional information about the problem or it can display the SCSI error code generated as M4sxxsxx where the xx's represent the additional sense code and qualifier.
Load Tape x	Status	Loads cassette x into the drive, where x represents the number of the cassette being loaded.
Locate Tape x	Status	The drive is finding a location on the tape specified by the host. x represents the number of the cassette.
Magazine Eject	Status	The DAT AutoLoader is ejecting the magazine.
Magazine Loading	Status	Indicates a magazine has been inserted and is moving into position in the AutoLoader.
Medium Error 03xxxxxx	Error	This is a medium error. There was a problem reading or writing data to the cassette. A SCSI error code can be displayed on the 3 <sup>rd</sup> line as M3sxxsxx where the xx's represent the additional sense code and qualifier.
Move Medium x => Drv	Error	Moves cassette x from the magazine to the drive, where x represents the cassette number.

*continued*

**Table 4-1**  
**LCD Messages - Alphabetical Listing** *continued*

LCD Message	Message Type	Meaning
Move Medium x => Mag	Error	Moves cassette x from the drive to the magazine, where x represents the cassette number.
No Magazine	Status	There is no magazine in the AutoLoader. The DAT AutoLoader is ready for a magazine to be inserted.
Read Tape x	Status	Cassette x is being read. x represents the number of the cassette.
Ready	Status	A magazine has been loaded in the AutoLoader and the Autoloader has completed scanning the cassettes and is ready for operation.
Ready Tape x	Status	Cassette x has been loaded into the drive and is ready for operation. x represents the number of the cassette.
Scan 1 Scan 2, etc	Status	The DAT AutoLoader is examining the cassettes in the magazine to check for proper magazine loading and configuration.
Select Prevent	Info	This message is displayed if the SCSI command "PREVENT MEDIA REMOVAL (LUN=0)" has been sent and the <b>Select</b> button is pressed.
Select x Load Tape x	Info	The cassette that has been selected is moving from the magazine into the drive.
Select x Push ENT	Info	Pressing the <b>Select</b> button displays the message "Select x". If <b>Select</b> is pressed again, x will increment to the next cassette, else the "Push ENT" will also be displayed. To load cassette x press the <b>Enter</b> button. If no button is pushed for a couple seconds, the command is cancelled. x represents the cassette number.
Select x Unload Tape y	Info	Cassette y is being returned to the magazine from the drive so that cassette x can be loaded. x and y represent different cassette numbers.
Send Diag Checking Mecha	Status	The diagnostics are checking the AutoLoader mechanics, such as the elevator, and so on.

*continued*

**Table 4-1**  
**LCD Messages - Alphabetical Listing** *continued*

LCD Message	Message Type	Meaning
Space Tape x	Status	The drive is moving the cassette x media to a specific location on the media. x represents the cassette number.
TSL10000 Self-Test Complete	Status	The DAT AutoLoader has performed its power-on self-test.
Unload Tape x	Status	A cassette is being ejected from the drive and returned to the magazine. x represents the cassette number.
Updating Firmware	Status	Firmware upgrade data is being read either from a cassette or the SCSI bus.
Verify Tape x	Status	The drive is verifying data on cassette x. x represents the cassette number.
Write Tape x	Status	The drive is writing data to cassette x. x represents the cassette number.

## LCD Menu Screens

To enter the menu mode, press and hold the **select** button for 5 seconds. The AutoLoader will exit the menu mode if no button is pressed within a 5-second period.

**Table 4-2**  
**LCD Menu Screens**

Menu Screen	Features
>Version Auto Load Unload Contrast Orientation Language	The main menu screen. Pressing the <b>Select</b> button advances the arrow to the next item on the menu: Prdrives.  Pressing the <b>Enter</b> button selects that sub menu.
TSL10000 SCSI ID#5 Ver.0000 S/NLxxxxxxx S/NDxxxxxxx	The version screen displays information about the autoloader including autoloader and drive serial numbers.
Auto Load  >OFF ON	The auto load screen allows the auto load feature to be turned on or off. Pressing the <b>Select</b> button moves the arrow to the other mode. Pressing the <b>Enter</b> button selects that mode. When auto load is ON and the AutoLoader is in the one cassette mode, the AutoLoader automatically loads the cassette into the drive.
Unload Continuous  >OFF ON	The Unload Continuous OFF selection only affects the AutoLoader when: 1) the AutoLoader is loaded with 8 cassettes, in the 8 cassette mode, 2) cassette #8 is in the drive and 3) a SCSI unload command is issued. The Autoloader will unload cassette #8 and stop. If Unload Continuous is ON, the AutoLoader will unload cassette #8 and then load cassette #1 into the drive. Pressing the <b>SELECT</b> button moves the arrow to the next item on the menu. Pressing the <b>ENTER</b> button selects that mode.
Contrast Adjustment	The contrast adjustment screen allows the display's contrast to be adjusted. Pressing the <b>Select</b> button increases contrast until maximum contrast is reached. Pressing <b>Select</b> again changes the display to minimum contrast. The number of darkened bars (see Figure 4-10, Cassettes position) on the bottom indicates the relative magnitude of the contrast.

*continued*

**Table 4-2**  
**LCD Menu Screens** *continued*

<b>Menu Screen</b>	
Orientation	The orientation screen allows a different display orientation to be selected when the drive is mounted on a different axis. Pressing the <b>Select</b> button will advance the arrow to the next item on the menu. Pressing the <b>Enter</b> button will select that orientation.
>Horizontal	
R-side down	
L-side down	
Language	This is the language screen. Pressing the <b>Select</b> button advances the arrow to the next language on the menu. Pressing <b>Enter</b> button selects that language. Then all messages will be displayed in that language.
>English	
French	
German	
Spanish	

# Chapter 5

## Cleaning

Reliable backup of your system is the product of at least four components:

- A reliable tape drive
- Quality tape cassettes
- Regular backup schedule with backup media stored offsite
- Routine tape drive maintenance

The Compaq 20/40 GB DAT 8-Cassette AutoLoader is designed to operate reliably under worst case conditions; however, it requires simple routine maintenance to operate efficiently. Regular cleaning is the most essential step in properly maintaining a tape drive and preventing errors.

For more information about cleaning Compaq tape drives, refer to the Compaq website address: <http://www.compaq.com>. Once on the site, search for “Whitepapers.”

### Importance of Routine Cleaning

---

**IMPORTANT:** Regular cleaning is vital to trouble-free operation of any tape device. Failure to follow recommended cleaning procedures could result in serious damage to your tape drive. Compaq recommends a routine cleaning every 100 hours of use.

---

Routine cleaning of a tape drive minimizes buildup on the read/write heads so that fewer cleaning cycles are required to keep the tape drive in good working order. When a tape drive is cleaned according to a regular schedule, one cleaning cycle typically removes accumulated dirt and particle deposits. If the

drive is not cleaned regularly, however, up to 4 cleaning cycles may be necessary to fully clean the drive.

Compaq recommends a routine cleaning schedule every 100 hours of use. In addition, the drive should be cleaned whenever the front panel LCD indicates.

Not all tape drives require the same frequency of cleaning to keep them operating efficiently. Factors such as the design of the tape drive and the quality of the tape media used for backups affect cleaning frequency.

## Errors Resulting from Cleaning Neglect

Following are some of the errors that can result from failure to observe routine maintenance and cleaning of tape drives:

- Dropouts — Caused by weak signal strength from dirty read/write heads, a dropout can result in reduced tape capacity and backup performance.
- Media errors — The backup tapes can be jammed, torn, or otherwise damaged by a dirty read/write head.
- Read or write errors — Because of a dirty read/write head, data may not have been recorded on the tape during backup. Even if the data is on the backup tape, retrieval may not be possible if the dirty head cannot read the data.
- Format failures — During backup, data is laid on the tape in a certain format for easy retrieval. A dirty write head can cause format failures, which means that data can be lost or impossible to retrieve.
- Bad blocks — Because of media damage (see Media errors above), the tape may not accept backup data. Also, the read/write head may be unable to retrieve data from bad blocks.

## Importance of Compaq-Approved Tape Cassettes

Compaq-approved tape cassettes are thoroughly tested to meet high-quality standards. Before Compaq recommends a tape cassette, the quality and reliability of the magnetic media and the cassette are evaluated. Do not use unapproved tape cassettes because they may not be compatible with Compaq tape drives.

See Chapter 1 for a list of Compaq-approved tape cassettes.

## DAT AutoLoader Cleaning Recommendations

Of the tape drives available today, DAT drives are more susceptible to buildup of contaminants. If a DAT drive is not kept clean, increased errors will occur. Recommendations for cleaning DAT drives are as follows:

- If the CLEANREQ message is displayed on the front panel.
- When using new tape cassettes, clean the drive heads with a cleaning cassette after every 8 hours of use for 5 initial cleanings.
- When using tape cassettes that have already been used 5 times, clean the drive heads with a cleaning cassette after every 100 hours of use.
- If you begin to experience read or write errors, format failures, or a number of bad blocks, clean the head and capstan 3 more times before concluding that either the tape or the tape drive is defective.
- In a dusty environment, one cleaning cycle may not fully clean the DAT AutoLoader drive read/write heads. If backup software reports errors, clean the drive again. No more than four cleanings will be required to ensure that heads are fully clean.

**NOTE:** Cleaning cassettes can be used approximately 50 times. An expired cleaning cassette will eject immediately without cleaning.



**CAUTION:** No other periodic maintenance is required. **Do Not** use alcohol or cleaning solution to clean DAT drives. **Do Not** clean read/write heads with a cotton swab. Fibers from a cotton swab can cause permanent damage to the head.

---



## Procedure for Cleaning the Heads in Stacker Mode

1. Place the cleaning cassette into one of the magazine positions (for example, position 8) and insert the magazine into the DAT AutoLoader.
2. Use the **Select** button to select the magazine position in which you placed the cleaning cassette.
3. Press the **Enter** button to load the cleaning cassette into the drive. The DAT AutoLoader will then automatically perform a cleaning cycle.
4. At the end of the cleaning cycle, the drive automatically ejects the cassette and the AutoLoader replaces it in the magazine.
5. Note the date on the label on the cleaning cassette, so that there is a record of how many times it has been used. After 50 uses, discard the cassette.

---

**IMPORTANT:** If a cleaning cassette is left permanently in the magazine, it will reduce the amount of data that can be backed up to the magazine, since it will only have seven positions available for data cassettes.

---

## Procedure for Cleaning the Heads in Random Mode

1. The host sends a MOVE MEDIUM command to move the cleaning cassette from the magazine to the drive. The DAT AutoLoader will only recognize the cleaning cassette once it is loaded into the drive.
2. The drive will then automatically perform a cleaning cycle.
3. The drive automatically ejects the cassette after the cleaning cycle is complete. The AutoLoader returns the cassette to its magazine position without further host involvement.

In Random mode, the host can program a routine cleaning cycle (for example, once a week). The cleaning cassette remains in a set position, such as, position 8, ready for use at the designated time. Remember that this will reduce the amount of data you can back up to the magazine, since you will only have seven positions available for data cassettes.

# Chapter 6

## Troubleshooting

If a problem occurs with the Compaq 20/40 GB DAT 8-Cassette AutoLoader, the first step is to try and establish whether the problem lies with the cassette, the DAT AutoLoader, the host computer and connections, or the way the system is being operated.

### Quick Checklist

Listed below are some hardware and software related items that potentially could cause DAT AutoLoader failures. These items are covered in more detail under Eliminating Resource Conflicts, Installation, and Resolving Operating Problems.

### Hardware

Make sure the following tasks have been properly completed:

- Determine whether the cassette is the cause of the problem:
  - ❑ Check that you are using a DDS-labeled cassette. Do not use a non-DDS cassette.
  - ❑ Are you trying to write to non-MRS media? (See Chapter 1, “DDS Logo Media.”)
  - ❑ Is the cassette write-protected?
  - ❑ If the problem still occurs, try using a different cassette.

- Determine whether the Autoloader is the cause of the problem:
  - ❑ The DAT AutoLoader heads have been cleaned within the last eight hours of use.
  - ❑ Verify the DAT AutoLoader switches and jumpers have been set correctly.
  - ❑ The power and signal cables are connected correctly and the controller is seated properly.
  - ❑ If multiple SCSI devices are used, be sure that each device has a unique SCSI ID.
  - ❑ The DAT AutoLoader passes the Compaq Diagnostics test.
  - ❑ Check to make sure you have the latest Options ROMPaq.
  - ❑ Run Compaq System Configuration Utility and check for conflicts.

## **Software**

Make sure that:

- The correct software drivers are being used. (Make sure that the operating system driver for the DAT AutoLoader matches the drive type.)
- The tape backup software supports the DAT AutoLoader hardware you are using.

If none of these software problems above apply, try reinstalling the tape backup software.

## Installation Troubleshooting

Follow the procedures in this section if the tape drive has not been operational since it was installed in the computer. Turn on the computer and insert the tape.

**Table 6-1**  
**Installation Troubleshooting**

Problem	Try This
Tape light on the tape drive does not turn on	<ul style="list-style-type: none"> <li>■ Make sure the tape drive power cable is connected.</li> <li>■ Remove the signal cable from the tape drive. If the light starts working, check for a defective cable, an incorrectly installed cable, or a defective controller.</li> <li>■ Replace the tape drive.</li> </ul>
Tape light on the tape drive turns on but drive does not respond to commands	<p>Run the Compaq System Configuration Utility from the hard drive or from diskette and restart the computer. Configure all boards in the system, then check the following:</p> <ul style="list-style-type: none"> <li>■ Verify that all installed boards appear in the slot diagram. Add any missing boards.</li> <li>■ Verify that the switch settings shown by the Compaq System Configuration Utility match the physical settings used on the boards. Ensure that the board settings match the settings shown by the utility.</li> </ul>
System Configuration Utility does not recognize the tape drive	<ul style="list-style-type: none"> <li>■ Check the connections of the signal cable.</li> <li>■ Check the seating of the controller.</li> <li>■ If multiple SCSI devices are used, ensure that each device has a unique SCSI ID.</li> <li>■ Your drive should be shipped from the factory with all terminators removed. Verify that all terminators have been removed.</li> <li>■ If none of these steps solve the problem then remove, replace and test each of the following components separately: signal cable, tape drive, and finally the controller.</li> </ul>

## Troubleshooting After Installation

Follow the procedures in this section if the DAT AutoLoader has stopped operating:

1. Run the Diagnostics utility.
2. Clean the DAT AutoLoader heads, card, and magazine loaders.
3. Replace the tape cassette.
4. If multiple DAT AutoLoaders or tape drives are used, ensure that each tape drive has a unique SCSI ID. **(Default=6)**
5. Your DAT AutoLoader should be shipped from the factory with all terminators removed. Verify that all terminators have been removed.
6. Check the controller, signal cable, and power cable connections to ensure that they are properly seated.
7. Replace the cables, DAT AutoLoader, and finally the controller.

### For Tru64 Unix

If drivers are not seen, Refer to the “Digital layered product” CD-ROM distribution disc for kernel rebuilding information. Search for *SCSI CAM Layered Components for Tru64 UNIX Systems Version 3.1E Installation Guide*.

Installation information can also be found online. For instructions on locating release notes and other information see the, *Software Product Library CD-Rom User Guide*.

### For Novell NetWare

Refer to the *STORAGE.RDM* file on the Support Software for Novell Products (NSSD) diskette which was supplied with your workstation, server, or DAT AutoLoader for troubleshooting information.

## For Microsoft Windows NT Systems

**NOTE:** The following procedures apply only for Microsoft Windows NT 4.0 and above.

1. Confirm that the SCSI controller software driver has been installed and started.
  - a. Use the Windows NT Setup program or SCSI Adapters applet on the Control Panel to determine if the driver is installed.
  - b. Use the Devices or SCSI Adapters applet on the Control Panel to determine if the driver is started.
  - c. If necessary, reinstall the driver.
2. Confirm that the DAT AutoLoader driver has been installed and started.
  - a. Use the Windows NT Setup program or Tape Devices applet on the Control Panel to determine if the driver is installed.
  - b. Use the Devices or Tape Devices applet on the Control Panel to determine if the driver is started.
  - c. If necessary, reinstall the driver.

## For SCO OpenServer Systems

1. Verify that the tape driver is configured in the kernel.
  - a. Use the HWCONFIG command or view the bottom of the file, `/usr/adm/messages`, to determine whether the driver is installed or to determine the current tape parameters.
  - b. Use the MKDEV TAPE command to install the driver in the kernel or to modify the current tape parameters.
2. If you are using the DAT AutoLoader to install SCO OpenServer and a Fast SCSI-2 Controller, verify that the DAT AutoLoader is connected to the Fast SCSI-2 Controller.

## For IBM OS/2 Systems

The correct tape driver must be installed for the DAT AutoLoader to work with OS/2. Try the following:

1. Install the tape software again.
2. Make sure that a tape driver statement was added to the *CONFIG.SYS* file during the tape software installation procedure. If the tape driver statement is missing, edit the *CONFIG.SYS* file to add the statement. Refer to the tape software documentation for more information. Restart the server after making changes.

## Resolving Operating Problems

If the DAT AutoLoader worked previously but now does not, try the following:

1. Clean the drive heads.
2. Run the tape drive option of Compaq Diagnostics.
3. Determine what has changed in the system since the last tape backup.
  - a. If the system configuration has been changed, try removing the change to see if it affects the tape backup system.
  - b. If a board or option has been added, check its DMA, IRQ, and port address settings for conflicts. Try removing the board or option.
  - c. If a SCSI device has been added, check for SCSI ID conflicts and proper termination. **(Default=6)**
4. Check the DAT AutoLoader connections. Reseat the controller, SCSI signal cable, and power cable.

## Resolving Magazine Problems

If the DAT AutoLoader does not recognize the magazine, check the cassette configuration.

1. If there is a cassette in position 8 but less than 7 cassettes in the other positions the magazine will recognize the configuration as a single cassette.
2. If there is not a cassette in position 8 and all the other positions are not full, the magazine will be ejected.

## Correcting Intermittent Failures

If the DAT AutoLoader works only intermittently:

1. Clean the tape drive's heads.
2. Run the Compaq Diagnostics Utility and the tape drive Diagnostics Utility. Follow the steps listed in the Installation section of this chapter for the Compaq and tape diagnostics programs.
3. If the tape backup procedure starts correctly but then stops with an error:
  - a. Use test to check firmware revision level.
  - b. If the error occurs on the same file or directory each time, remove that file or directory from the backup list because it may be corrupted. Correct any errors that you find with the file system.
4. If the tape backup procedure starts correctly, but stops intermittently:
  - a. Check the DMA, IRQ, and port address settings for conflicts. If there is a conflict, change the setting or remove the conflicting board.
  - b. Try using a new tape cassette.

Check to make sure the DAT autoloader has the latest upgrade. If not, upgrade to the latest version. (Refer to the Compaq website address listed at the front of this guide for the latest options SoftPaq).



## **Regulatory Compliance Notices**

### **Regulatory Compliance Identification Numbers**

For the purpose of regulatory compliance certifications and identification, your DAT AutoLoader is assigned a Compaq Series Number. The Compaq Series number for this product is: Series EO 2005 DDS4 External EOD 007 DDS4 Internal. The DAT AutoLoader Series Number can be found on the product label, along with the required approval markings and information. When requesting certification information for this product always refer to this Series Number. This series number should not be confused with the marketing name or model number for your DAT AutoLoader.

### **Federal Communications Commission Notice**

Part 15 of the Federal Communications Commission (FCC) Rules and Regulations has established Radio Frequency (RF) emission limits to provide an interference-free radio frequency spectrum. Many electronic devices, including computers, generate RF energy incidental to their intended function and are, therefore, covered by these rules. These rules place computers and related peripheral devices into two classes, A and B, depending upon their intended installation. Class A devices are those that may reasonably be expected to be installed in a business or commercial environment. Class B devices are those that may reasonably be expected to be installed in a residential environment (that is, personal computers). The FCC requires

devices in both classes to bear a label indicating the interference potential of the device as well as additional operating instructions for the user.

The rating label on the device shows which class (A or B) the equipment falls into. Class B devices have an FCC logo or FCC ID on the label. Class A devices do not have an FCC ID on the label. Once the class of the device is determined, refer to the following corresponding statement.

## **Class B Equipment**

This equipment has been tested and found to comply with the limits for a Class B digital device, pursuant to Part 15 of the FCC Rules. These limits are designed to provide reasonable protection against harmful interference in a residential installation. This equipment generates, uses, and can radiate radio frequency energy and, if not installed and used in accordance with the instructions, may cause harmful interference to radio communications. However, there is no guarantee that interference will not occur in a particular installation. If this equipment does cause harmful interference to radio or television reception, which can be determined by turning the equipment off and on, the user is encouraged to try to correct the interference by one or more of the following measures:

- Reorient or relocate the receiving antenna.
- Increase the separation between the equipment and receiver.
- Connect the equipment into an outlet on a circuit different from that to which the receiver is connected.
- Consult the dealer or an experienced radio or television technician for help.

**Declaration of Conformity for Products Marked  
with the FCC logo – United States Only**

This device complies with Part 15 of the FCC Rules. Operation is subject to the following two conditions: (1) this device may not cause harmful interference, and (2) this device must accept any interference received, including interference that may cause undesired operation.

For questions regarding your product, contact:

Compaq Computer Corporation  
P. O. Box 692000, Mail Stop 530113  
Houston, Texas 77269-2000

or call 1-800- 652-6672 (1-800-OK COMPAQ). (For continuous quality improvement, calls may be recorded or monitored.)

For questions regarding this FCC declaration, contact:

Compaq Computer Corporation  
P. O. Box 692000, Mail Stop 510101  
Houston, Texas 77269-2000

or call (281) 514-3333.

To identify this product, refer to the Part, Series, or Model number found on the product.

**Modifications**

The FCC requires the user to be notified that any changes or modifications made to this device that are not expressly approved by Compaq Computer Corporation may void the user's authority to operate the equipment.

## Canadian Notice (Avis Canadien)

### Class B Equipment

This Class B digital apparatus meets all requirements of the Canadian Interference-Causing Equipment Regulations.

Cet appareil numérique de la classe B respecte toutes les exigences du Règlement sur le matériel brouilleur du Canada.

## European Union Notice

Products with the CE Marking comply with both the EMC Directive (89/336/EEC) and the Low Voltage Directive (73/23/EEC) issued by the Commission of the European Community.

Compliance with these directives implies conformity to the following European Norms (in brackets are the equivalent international standards):

- EN55022 (CISPR 22) - Electromagnetic Interference
- EN50082-1 (IEC801-2, IEC801-3, IEC801-4) - Electromagnetic Immunity
- EN60950 (IEC950) - Product Safety

## Japanese Notice

ご使用になっている装置にVCCIマークが付いていましたら、次の説明文をお読み下さい。

この装置は、情報処理装置等電波障害自主規制協議会（VCCI）の基準に基づくクラスB情報技術装置です。この装置は、家庭環境で使用することを目的としていますが、この装置がラジオやテレビジョン受信機に近接して使用されると、受信障害を引き起こすことがあります。

取扱説明書に従って正しい取り扱いをして下さい。

VCCIマークが付いていない場合には、次の点にご注意下さい。

この装置は、情報処理装置等電波障害自主規制協議会（VCCI）の基準に基づくクラスA情報技術装置です。この装置を家庭環境で使用すると電波妨害を引き起こすことがあります。この場合には使用者が適切な対策を講ずるよう要求されることがあります。

## Taiwanese Notice

警告使用者：

這是甲類的資訊產品，在居住的環境中使用時，可能會造成射頻干擾，在這種情況下，使用者會被要求採取某些適當的對策。

## *Appendix* **B**

# **Electrostatic Discharge**

To prevent damaging the system, be aware of the precautions you need to follow when setting up the system or handling parts. A discharge of static electricity from a finger or other conductor may damage system boards or other static-sensitive devices. This type of damage may reduce the life expectancy of the device.

To prevent electrostatic damage, observe the following precautions:

- Avoid hand contact by transporting and storing products in static-safe containers.
- Keep electrostatic-sensitive parts in their containers until they arrive at static-free workstations.
- Place parts on a grounded surface before removing them from their containers.
- Avoid touching pins, leads, or circuitry.
- Always be properly grounded when touching a static-sensitive component or assembly.

## Grounding Methods

There are several methods for grounding. Use one or more of the following methods when handling or installing electrostatic-sensitive parts:

- Use a wrist strap connected by a ground cord to a grounded workstation or computer chassis. Wrist straps are flexible straps with a minimum of 1 megohm  $\pm$  10 percent resistance in the ground cords. To provide proper ground, wear the strap snug against the skin.
- Use heel straps, toe straps, or boot straps at standing workstations. Wear the straps on both feet when standing on conductive floors or dissipating floor mats.
- Use conductive field service tools.
- Use a portable field service kit with a folding static-dissipating work mat.

If you do not have any of the suggested equipment for proper grounding, have an Authorized Compaq Reseller install the part.

**NOTE:** For more information on static electricity, or assistance with product installation, contact your Authorized Compaq Reseller.

# Appendix **C**

## Specifications

### Dimensions and Weight

---

**Table C-1**  
**Dimensions and Weight**

<b>Dimension</b>	<b>Internal AutoLoader</b>		<b>Tabletop AutoLoader</b>	
Height	82.5 mm	3.50 in	109.5 mm	4.31 in
Width	146 mm	5.75 in	211 mm	8.31 in
Depth	241.6 mm	9.51 in	295.5 mm	11.63 in
Weight	2.4 kg	5.28 lbs	5 kg	11 lbs



## Temperature and Humidity Range

**Table C-2**  
**Temperature and Humidity**

Actions	Temperature	Humidity
Operating	5°C to 40°C ( $\Delta T < 10^\circ\text{C/h}$ )	20 to 80% RH, non-condensing Maximum wet bulb temperature = 26°C
Non-Operating (mech.)	-40°C to 70°C ( $\Delta T < 20^\circ\text{C/h}$ )	5 to 95% RH ( $\Delta T < 30^\circ\text{C/h}$ )
Non-Operating (tape)	-40°C to 45°C ( $\Delta T < 20^\circ\text{C/h}$ )	20 to 80% RH ( $\Delta T < 30^\circ\text{C/h}$ )

**NOTE:** Do not cover fan. The tape drive can malfunction if the internal temperature rises too high.

## Power Requirements

**Table C-3**  
**Power Requirements**

Voltage	Max Ripple	Current	
		Typical	Maximum
5V +/- 5%	100 mVp-p	1.55A	2.5A
12V +/- 10%	100 mVp-p	0.35A	1.2A

## Air-Cooling Requirement

**Table C-4**  
**Air-cooling Requirements**

Ambient temperature	< 40°C
---------------------	--------

## Suspended Particulate

---

**Table C-5**  
**Suspended Particulate**

---

<b>Action</b>	<b>Feature</b>
Operating	Less than 150 microgram/m <sup>3</sup> Based sampling period 24 hours

---

# Index

## A

- Advanced SCSI Programming
  - Interface (ASPI) 3-3
    - driver 3-3
- air-cooling requirement C-2
- ANSI 1-5
- ARCserve from Compaq 3-3
- ASPI support 3-3
- AutoLoader operation
  - troubleshooting 6-4
- avoiding jams 4-2

## B

- backup software 1-8
- backups
  - maximum number of 1-7
  - time required for 1-4
  - under extreme conditions 1-7
- bad blocks 5-2
- Banyan VINES 3-1, 3-8
  - drivers for hardware 3-8
  - drivers for SCSI controller 3-8
  - drivers for software 3-8
- Beginning of Media *See* BOM
- Beginning of Partition *See* BOP
- BOM 4-7
- boot straps, using B-2
- BOP 4-7

## C

- cables
  - signal 2-9
- Canadian Notice (Avis Canadien) A-4
- cassettes
  - Compaq approved 1-5
  - compatibility 1-5
  - configurations in a magazine 4-2
  - DDS formats 1-2, 1-5, 4-1
  - DDS Logo Media 1-6
  - DDS Logo Media,
    - illustrated 1-6
  - eight cassette positions,
    - illustrated 4-4
  - forcing ejection 4-8
  - formats 1-5
  - identification 1-7
  - incorrect configuration 4-6
  - inserting in a magazine,
    - illustrated 4-5
  - labeling 4-2
  - life expectancy 1-7
  - loading the magazine 4-2, 4-5
  - MRS 1-6
  - positions in the magazine 4-5
  - removing from the magazine 4-6

## 2 Compaq DAT AutoLoader Reference Guide

- seven cassette positions,
  - illustrated 4-4
- single cassette position,
  - illustrated 4-4
- standards 1-5
- tape log 1-7
- troubleshooting 6-1, 6-2
- write-protecting 1-7
- CE Marking A-4
- cleaning
  - cycle 5-3
  - errors from neglect 5-2
  - importance of approved tapes 5-3
  - importance of routine 5-1
  - procedures in random mode 5-4
  - procedures in stacker mode 5-4
  - random mode 5-4
  - recommendations 5-3
  - recommended schedule 5-2
  - stacker mode 5-4
  - whitepapers on 5-1
- cleaning the DAT AutoLoader and frequency of backups 1-4
- Compaq authorized reseller x
- Compaq Extended Feature Supplement *See* EFS
- Compaq Series Number A-1
- Compaq Tru64 UNIX 3-1, 3-4
  - drivers for hardware 3-4
  - drivers for SCSI controller 3-4
  - drivers for software 3-4
- Compaq website x
- computer
  - capacity 1-4
  - performance 1-8
- configuring SCSI ID for SCO OpenServer 3-5
- configuring the AutoLoader 2-2
- connecting the tabletop AutoLoader 2-9
- controller drivers
  - Banyan VINES 3-8
  - Compaq Tru64 UNIX 3-4

- OpenVMS 3-4
- SCO UnixWare 3-6
- SunSoft Solaris 3-7
- Windows NT 3-2

controller requirements 1-3

## D

- daisy chain 2-10
- DAT AutoLoader
  - capacity 1-4
  - illustrated 1-1
  - projected duty cycle of 1-4
  - reliability 1-3
- DAT cassettes 4-1
- data compression 1-2
  - enabling and disabling 1-5
  - overview 1-4
- DDR *See* Dynamic Device Recognition
- DDS cassettes 1-2, 1-5, 4-1
- DDS-DC format 1-2, 1-4, 1-5
- Declaration of Conformity A-3
- device drivers 3-1
- dropouts 5-2
- duty cycle 1-4
- Dynamic Device Recognition 3-4

## E

- ECMA 1-5
- EFS
  - for SCO OpenServer 3-5
  - for SCO UnixWare 3-7
- eject button 4-7, 4-9
- electrostatic discharge
  - obtaining additional information B-2
  - precautions B-1
  - preventing B-1
  - storing products B-1
  - transporting products B-1
  - types of damage from B-1
- electrostatic discharge (ESD) 2-6
- End of Data *See* EOD
- enter button 4-9

environmental conditions 1-7  
 EOD 4-9  
 ESD *See* electrostatic discharge  
 European Union Notice A-4  
 Extended Feature Supplement *See*  
 EFS

## F

FCC Class B compliance  
 notice A-2  
 Federal Communications  
 Commission (FCC) notice A-1  
 For Tru64 Unix 6-4  
 forcing cassette ejection 4-8  
 format failures 5-2  
 front panel  
 Busy LED 4-10  
 eject button 4-10  
 enter button 4-10  
 features 4-10  
 identifying 4-10  
 LCD 4-10, 4-11  
 magazine slot 4-10  
 select button 4-10  
 tape LED 4-10

## G

getting help x  
 grounding methods B-2  
 grounding straps  
 specifications B-2  
 wearing B-2  
 grounding, suggested equipment  
 for B-2

## H

hardware settings 2-2  
 default 2-2  
 hardware troubleshooting 6-1  
 heel straps, using B-2  
 help  
 additional sources x  
 Compaq website x

Compaq authorized resellers,  
 telephone numbers x  
 technical support telephone  
 numbers x  
<http://www.compaq.com> x  
 humidity range C-2

## I

IBM OS/2  
 troubleshooting 6-6  
 icons  
 symbols on equipment viii  
 incorrect cassette  
 configuration 4-6  
 indicators  
 LED 6-6  
 installation  
 overview 2-1  
 setting the options  
 switches 2-3  
 setting the SCSI ID 2-3, 2-9  
 software drivers 3-1  
 software requirements 2-1  
 tabletop AutoLoader 2-9  
 the drive with rails 2-6  
 the drive with rails,  
 illustrated 2-6  
 the drive without rails 2-7  
 the drive without rails,  
 illustrated 2-7  
 tools needed 2-1

## J

jams, avoiding 4-2

## L

labeling  
 cassettes 4-2  
 the magazine 4-2  
 LCD 1-2, 4-11  
 cassette odometer 1-2  
 features 4-11  
 illustrated 4-11

## 4 Compaq DAT AutoLoader Reference Guide

- LCD menu screens 4-16
  - Auto Load 4-16
  - Contrast Adjustment 4-16
  - Language 4-17
  - Orientation 4-17
  - TSL9000 SCSI ID#5
    - Ver.0000 4-16
  - Version 4-16
- LCD messages 4-12
  - Cassette Stuck in Drive 4-12
  - Cleaning Failed
    - CleanReq 4-12
  - Cleaning in Process 4-12
  - CleanReq 4-12, 5-3
  - Drv HW Error 4-12
  - Eject Prevent 4-12
  - Ejecting Magazine 4-12
  - Erase Tape x 4-13
  - Illegal Cassette Config 4-13
  - Illegal Magazine Config 4-13
  - Init Element Status 4-13
  - Ldr HW Error ResetReg 4-13
  - Load Tape x 4-13
  - Locate Tape x 4-13
  - Magazine Eject 4-13
  - Magazine Loading 4-13
  - Medium Error 4-13
  - Move Medium x => Drv 4-13
  - Move Medium x => Mag 4-14
  - No Magazine 4-14
  - Read Tape x 4-14
  - Ready 4-14
  - Scan 1, Scan 2 4-14
  - Select Load Tape x 4-14
  - Select Prevent 4-14
  - Select x Push ENT 4-14
  - Select x Unload Tape y 4-14
  - Send Diag Checking
    - Mecha 4-14
  - Space Tape x 4-15
  - TSL9000 Self-Test
    - Complete 4-15
  - Unload Tape x 4-15
  - Updating Firmware 4-15
  - Verify Tape x 4-15
  - Write Tape x 4-15

## M

- magazine
  - cassette configurations 4-2
  - ejecting 4-7
  - identification 4-2
  - incorrect cassette
    - configuration 4-6
  - inserting cassettes 4-5
  - labeling 4-2
  - loading into the
    - AutoLoader 4-6
  - loading into the AutoLoader,
    - illustrated 4-6
  - loading with cassettes 4-2, 4-5
  - removing cassettes 4-6
- media errors 5-2
- Media Recognition System *See*
  - MRS
- Microsoft Windows NT *See*
  - Windows NT
- modes of operation 4-9
  - random mode 4-9
  - stacker mode 4-9
- modifications
  - FCC compliance
    - statement A-3
- MRS 4-1

## N

- Novell NetWare 3-1, 3-3
  - troubleshooting 6-4

## O

- OpenVMS 3-1, 3-4
  - drivers for hardware 3-4
  - drivers for SCSI controller 3-4
  - drivers for software 3-4
- operation of AutoLoader
  - modes of 4-9

## P

- parts

- proper handling B-1
- storing B-1
- transporting B-1
- power requirements C-2
- problems *See* troubleshooting

## R

- random mode 4-9, 5-4
  - cleaning 5-4
- read or write errors 5-2
- recommendations
  - cleaning 5-3
- regulatory compliance
  - identification number A-1
- removing cassettes from the magazine 4-6
- RJ-45 receptacle viii

## S

- SCO OpenServer 3-1, 3-4
  - software driver
    - information 3-5
    - troubleshooting 6-5
- SCO UnixWare 3-1, 3-6
  - drivers for hardware 3-6
  - drivers for SCSI controller 3-6
  - drivers for software 3-6
- SCSI commands
  - ENABLE MEDIA
    - REMOVAL 4-8
  - MEDIUM CHANGER 4-9
  - MOVE MEDIUM 4-9, 5-4
  - PREVENT MEDIA
    - REMOVAL 4-8, 4-9, 4-12, 4-14
  - UNLOAD 4-7, 4-8, 4-9
- SCSI ID 2-3
  - default 2-9
  - ID 7 2-3
  - jumper pins, illustrated 2-2
- SCSI-2
  - controller 1-3
  - features 1-3
  - functions 1-3

- interface 1-2, 1-3
- Seagate BackupExec 3-3
- select button 4-9
- sequential mode *See* stacker mode
- series number A-1
- signal cable 2-9
- slide stopper 4-6
  - illustrated 4-7
- SmartStart and Support Software CD 2-2
- software driver information
  - Banyan Vines 3-8
  - Novell NetWare 3-3
  - SCO UnixWare 3-6
  - SunSoft Solaris 3-7
  - Windows NT 3-2
- software drivers
  - Banyan VINES 3-8
  - installing 3-1
  - SCO UnixWare 3-6
  - SunSoft Solaris 3-7
  - Windows NT 3-2
- software requirements 2-1
- software troubleshooting 6-2
- stacker mode 4-9, 5-4
  - cleaning 5-4
- static-safe containers
  - storing products in B-1
  - transporting products in B-1
- SunSoft Solaris 3-1, 3-7
  - drivers for hardware 3-7
  - drivers for SCSI controller 3-7
  - drivers for software 3-7
- suspended particulate C-3
- switches
  - defaults 2-4
  - illustrated 2-4
  - MRS 2-4
  - self-test 2-4
  - settings 2-3
- symbols in text viii
- symbols on equipment viii
- system shutdown 2-6
- system, preventing electrostatic damage to B-1

## **T**

- tabletop AutoLoader
  - installation 2-9
  - SCSI ID 2-9
- tape drive switch configuration 2-3
  - defaults 2-3
  - illustrated 2-4
- TapeAlert 1-2
- technical support x
- telephone numbers x
- temperature range C-2
- text conventions vii
- tool requirements 2-1
- tools
  - conductive field service type B-2
- troubleshooting
  - after installation 6-4
  - cassettes 6-1, 6-2
  - hardware 6-1
  - IBM OS/2 Systems 6-6
  - installation 6-3
  - intermittent failures 6-7
  - magazine problems 6-6

- MRS 6-1
- Novell NetWare 6-4
- operating problems 6-6
- quick checklist 6-1
- SCO OpenServer 6-5
- software 6-2
- Windows NT 6-5

## **W**

- warnings
  - electrical shock ix
  - rack stability ix
- Windows NT 3-1
  - drivers for hardware 3-2
  - drivers for SCSI controller 3-2
  - drivers for software 3-2
  - systems troubleshooting 6-5
- wrist straps
  - specifications B-2
  - using B-2
- www.compaq.com x